

Copyright
by
Shannon M. Hedtke
2009

**The Dissertation Committee for Shannon M. Hedtke
certifies that this is the approved version of the following dissertation:**

**ORIGIN AND MAINTENANCE OF ANDROGENESIS:
MALE ASEXUAL REPRODUCTION IN THE CLAM GENUS *CORBICULA***

Committee:

David Hillis, supervisor

James Bull

David Cannatella

C. Randall Linder

Kenneth Young

**ORIGIN AND MAINTENANCE OF ANDROGENESIS:
MALE ASEXUAL REPRODUCTION IN THE CLAM GENUS *CORBICULA***

by

Shannon M. Hedtke, B.A.

Dissertation

Presented to the Faculty of the Graduate School of

The University of Texas at Austin

in Partial Fulfillment

of the Requirements

for the Degree of

Doctor of Philosophy

The University of Texas at Austin

May 2009

Dedication

To A. and B.

Acknowledgements

While at the University of Texas, Austin, I have received a lot of help, advice, and guidance from the members of the Hillis and Bull labs over the years. Out in the field, Amy Baird, David Bickford, Erin and Jeremy Brown, Rick Heineman, Manda Jost, Rachael Springman, and Beckie Symula waded around in freezing February weather to catch clams. Beckie braved the strange and wonderful world of west Texas with me to catch additional *Corbicula*. I also received specimens critical to my research from the following people: J. Bickham, R. Butler, D. Hall, C. Ituarte, D. Ó Foighil, M. Sredl, A. de Vaate, J. Williams, and particularly from M. Glaubrecht.

My labwork was funded by grants from the Section of Integrative Biology at UT-Austin and a National Science Foundation Doctoral Dissertation Improvement Grant. Several students assisted me in the lab: David Mata, Camille Moray, Bharat Rhamesh, Gretchen Ryan, Jenni Soliz, and Nellie Wilson. Marty Badgett did the restriction digest work and Robert Baker the *in-situ* hybridization described in Chapter 2. I appreciate Dr. Baker's diligent efforts working with me trying (unsuccessfully) to karyotype North American *Corbicula*. Rick Heineman used a number of dangerous chemicals for me while I was pregnant. Advice and empathy was provided by the "Estroden" (Meredith Mahoney and Amy Baird), Jeremy Brown, Brian Caudle, Will Harcombe, Tracy Heath, Rick Heineman, Alisha Holloway, Thomas Keller, Alan and Emily Lemmon, Emily McTavish, Matt Morgan, Greg Pauly, Beckie Symula, and Derrick Zwickl. When I first arrived at UT, Kathrin

Stanger-Hall took me under her wing and taught me about *Corbicula* and about being a good scientist and a good mother. I thank the members of my committee for contributing discussions on project design and critical feedback on manuscripts: Jim Bull, Dave “Catfish” Cannatella, Randy Linder, and Ken Young. Additional helpful comments on draft manuscripts have come from Jeff Chen, Tim Collins, Jerry Coyne, Mark Kirkpatrick, Bob Jansen, Diarmaid Ó Foighil, Beryl Simpson, Jonathan Wendel, and several anonymous reviewers.

Camille Parmesan and Mathew Leibold helped me develop ecological experiments about *Corbicula*. While these experiments lamentably failed, Tony Alexander and John Crutchfield kept an eye on things for me at UT's Brackenridge Field Lab while they were running.

I could not have gotten to UT without the help of some really excellent people. I wish to acknowledge my late boss at the Music Library at Cornell University, Lenore Coral. Without her combination of flexibility and tenacious defense of her employees, I would not have been able to go back to school. Kelly Zamudio at Cornell University brought me into her lab, and while I’ll have nightmares about salamander breeding seasons for years to come, she gave me a fantastic opportunity to learn.

My advisor, David Hillis, accepted me as a graduate student even though I had no prior degrees in any scientific field (I now know that what he was really looking for was people to be in his band, Phylozydeco). His guidance is greatly valued.

My mom and dad nurtured my love of nature. I remember my dad turning

over rocks in streams to point out bug larvae and other interesting critters when I was young. I appreciate their encouragement and support.

My husband, Ian Woolford, proposed while helping me sort *Corbicula* in the rain. Our daughters, Addie and Bixie, have cheered their grad student parents on every day of their lives.

**ORIGIN AND MAINTENANCE OF ANDROGENESIS:
MALE ASEXUAL REPRODUCTION IN THE CLAM GENUS *CORBICULA***

Shannon M. Hedtke, Ph.D.

The University of Texas at Austin, 2009

Supervisor: David M. Hillis

Asexual species which never incorporate novel genetic material from other lineages will go extinct faster than sexually reproducing species, because adaptive variability may be lower and a larger number of harmful mutations may accumulate. One form of asexuality, androgenesis, results in offspring that are clones of the father. Both androgenetic and sexual species are found in the clam genus *Corbicula*. I used genetic data to explore why there are multiple species of androgenetic *Corbicula*, and whether genetic exchange occurs between species. I found that in North American locations where two invasive, androgenetic species co-occur, restriction digest mapping of rDNA failed to detect recent nuclear exchange. However, in these same locations, mitochondrial markers were shared between species. In places where only one species was found, mitochondrial markers were unique to that species. This suggests androgenetic clams are able to parasitize eggs of closely related species. Whereas maternal mitochondria are retained in the fertilized egg, maternal nuclear chromosomes are expelled, and the mother incubates male clones of another species.

To look at possible gene exchange over the long term, I compared phylogenetic tree topologies of one mitochondrial and two nuclear markers from multiple sexual and androgenetic species. Since several androgenetic species share similar or identical alleles, androgenesis seems to have evolved relatively recently in *Corbicula*. However, since different androgenetic species also have divergent alleles not shared between species, genetic capture of maternal nuclear DNA from other species may rarely occur. This rare capture of genetic material from other species may permit the long-term persistence of androgenesis in *Corbicula*.

Table of Contents

List of Tables	xi
List of Figures	xii
Chapter 1: Avoiding the Costs of Clonal Reproduction.....	1
Chapter 2: Implications for Androgenesis from <i>Corbicula</i> in the Americas	27
Chapter 3: The Origin and Maintenance of Androgenesis in <i>Corbicula</i>	60
Chapter 4: The Role of Androgenesis in Cytoplasm Capture	98
References.....	114
Vita	129

List of Tables

Table 2.1: Sampling locations of <i>Corbicula</i> species, and numbers of clams from each sampling location used in a particular laboratory procedure.....	48
Table 2.2: GenBank numbers and localities for each haplotype designation	50
Table 2.3: Data on mismatches between mitochondrial haplotype and species identification for North and South American <i>Corbicula</i>	53
Table 2.4: Bayesian posterior probabilities of alternative tree topology hypotheses, given a post-burn-in sample of 181,912 trees.....	54
Table 3.1: Species of <i>Corbicula</i> sequenced, and the number of sequences obtained through cloning, for multiple nuclear loci.....	83
Table 3.2: PCR amplification results from <i>Corbicula</i> genomic DNA for various primers for nuclear and mitochondrial genes.	85
Table 3.3: Posterior probabilities of monophyletic groups in three different gene trees of <i>Corbicula</i>	87
Table 4.1: Organisms demonstrated to have reproduced through androgenesis.	110

List of Figures

Figure 1.1:	Some modes of reproduction	25
Figure 1.2:	Relationships between nuclear alleles is dependent on origin of asexuality	26
Figure 2.1:	Example autoradiograms of Southern blots from restriction digests of A) form A and B) form B <i>Corbicula</i> genomic DNA, hybridized to radioactively-labeled 28aa primer	55
Figure 2.2:	Restriction-site maps of ribosomal DNA repeat regions in North American <i>Corbicula</i> form A and form B	56
Figure 2.3:	<i>In-situ</i> hybridization of ribosomal RNA repeats in invasive form A and form B collected from San Gabriel River, Texas, USA	57
Figure 2.4:	Bayesian consensus phylogenies for North American <i>Corbicula</i> populations, with branch lengths optimized under maximum likelihood	58
Figure 2.5:	Bayesian consensus tree of the mitochondrial COI locus across haplotypes of <i>Corbicula</i> (see Table 2.2.), with branch lengths optimized under maximum likelihood	59
Figure 3.1:	Maximum likelihood estimate of nuclear ribosomal marker 28S....	88
Figure 3.2:	Maximum likelihood estimate of the nuclear ribosomal first internal transcribed spacer (ITS-1)	89
Figure 3.3:	Maximum likelihood estimate of a putative nuclear tubulin intron (put-TUB)	90
Figure 3.4:	Maximum likelihood estimate of a putative nuclear INT intron	91
Figure 3.5:	Maximum likelihood estimate of the third intron of the nuclear alpha-amylase gene (AMY) based on clone sequence data	92
Figure 3.6:	Maximum likelihood estimate of the third intron of the nuclear alpha-amylase gene (AMY) using sequences binned by similarity.	93
Figure 3.7:	Maximum likelihood estimate of a putative nuclear intron of ATPS-alpha (put-ATPS)	94

Figure 3.8: Bayesian consensus trees built from concatenated sequences of three markers: COI, AMY, and put-ATPS	95
Figure 3.9: The tangled relationships between mitochondrial and nuclear markers in androgenetic <i>Corbicula</i>	96
Figure 4.1: Androgenesis can cause phylogenetic discordance between trees built from nuclear versus cytoplasmic markers	111
Figure 4.2: Introgression versus androgenesis in cytoplasm capture	112

Chapter 1. Avoiding the Costs of Clonal Reproduction

Sex occurs throughout the Tree of Life. Sex brings together genetic material from different lineages and mixes it up through recombination. Mechanisms for sex vary widely across groups of organisms. Bacteria reproduce asexually – offspring are genetic clones of their parent – but they still have mechanisms for sex, such as when they take up molecules of DNA from their environment. In plants and animals, sex has become coupled with reproduction. The evolution of sexual reproduction has led to the evolution of diverse mating behaviors – from gametic fusion to pollination, courtship displays and mate choice.

Although asexual reproduction is widely distributed across plants and animals, species that reproduce asexually are comparatively rare and tend to be of recent origin (Muller 1932; Maynard Smith 1978, 1989; Judson and Normark 1996). Asexual eukaryotes can be obligately asexual (they do not gain genetic material from others), cyclically asexual (they switch between sexual and asexual reproduction), rarely asexual (they produce clonal offspring once in a blue moon), or even only partially asexual (one set of chromosomes is inherited without recombination, but another set is swapped out between generations). The type of reproduction considered in this work is all-male asexuality, or *androgenesis*: offspring are clones of their father.

Because of the relative rarity of asexual reproduction, presumably there are costs to reproducing asexually that allow sexual lineages to outcompete their asexual relatives. This is a conundrum for evolutionary biologists, because asexuals are

expected to have an advantage over sexuals. For every one asexual required to produce offspring, two sexuals are needed – a male and a female. Therefore, if sexuals and asexuals are equally fertile, the asexual female has a two-fold advantage over sexuals and will produce more descendants (the “two-fold cost of males”; Maynard Smith 1978). From a genetic perspective, an asexual has a two-fold advantage because each of its offspring inherits all of the parent’s genes. A sexually reproducing parent passes on only half of its chromosomes to each of its progeny (the “two-fold cost of meiosis”; Maynard Smith 1978, 1989). Even with these apparent disadvantages, sexual reproduction still dominates plants and animals.

The literature on costs to asexuality is extensive, but the main ideas on genetic costs can be broadly summarized: 1) while clonal offspring are not identical to their parents because of mutations (changes in DNA base pairs which may affect the molecule made by a gene or the expression of that gene), asexuals generate adaptive variation only by mutation, while sexuals also generate variation through recombination; and 2) harmful mutations accumulate faster in asexuals than sexuals. When more than one asexual lineage is observed in a closely related group of organisms – such as the four species of androgenetic clams in the genus *Corbicula* – some process must either cause repeated generation of asexual lineages, or partially counteract these genetic costs and allow time for diversification. By understanding the reasons behind asexual diversity in empirical systems, we may better evaluate costs and benefits to both asexual and sexual reproduction.

GENETIC COSTS OF ASEXUAL REPRODUCTION

The primary effect of recombination is to break up linkage disequilibrium (also called gametic or gametic phase disequilibrium) between loci. Linkage disequilibrium occurs when alleles are associated with each other more frequently than would be expected by chance (Lewontin and Kojima 1960). Linkage disequilibrium can be caused by a wide variety of biological processes, including genetic drift, inbreeding, selection, and loci being physically located on the same molecule of DNA (in the absence of recombination) or physically close on that molecule (in the presence of recombination). The outcome of models examining the spread and maintenance of alleles that cause or increase the recombination rate depends on the process generating linkage disequilibrium. These models consider two broad fitness effects of recombination: first, although recombination may break up co-adapted gene complexes (when alleles in the parent interact beneficially), it also can bring together alleles which increase an organism's ability to adapt to its environment (particularly when that environment is changing spatially or temporally); and second, recombination allows selection to more effectively purge harmful alleles that accumulate under asexual reproduction. While most models examine the effect of recombination explicitly, segregation of a segmented genome may have similar effects (e.g., Kirkpatrick and Jenkins 1989, Antezana and Hudson 1997). The adaptation and mutation accumulation models are not mutually exclusive, and indeed multiple factors most likely explain the current distribution (ecological and

phylogenetic) of asexual lineages (Barton and Charlesworth 1998, West et al. 1999).

Asexuals have a reduced ability to adapt compared to sexuals

Fisher (1930) and Muller (1932) suggested that a sexual population may incorporate beneficial alleles faster than an asexual population if recombination creates a novel genotype by bringing together beneficial mutations. Stochastic forces due to small population size causes linkage disequilibrium (Muller 1964, Crow and Kimura 1965, Felsenstein 1974), and beneficial alleles at one locus become associated with deleterious alleles at other loci by genetic drift (Hill and Robertson 1966, Felsenstein 1974, Barton 1995). When a beneficial allele is trapped in a poor genetic background, the probability that it will spread is reduced. In asexual populations, clones with different beneficial mutations will compete with each other, further reducing the probability of an adaptive allele's fixation ("clonal interference", Gerrish and Lenski 1998). Alleles that increase recombination will be indirectly selected for because these alleles will tend to occur in association with genes at other loci that are beneficial (Maynard Smith 1989, Otto and Barton 1997, Barton and Charlesworth 1998, Barton and Otto 2005). When there is drift in a finite population subject to fluctuating selection, linkage disequilibrium caused by drift reduces genetic variability, and recombination rates are expected to rise over time as recombination disrupts linkage disequilibrium and increases genetic variance (Barton and Otto 2005, Martin et al. 2006).

Selection can also generate linkage disequilibrium in the absence of drift. Selection on favorable alleles will bring these alleles to higher frequency, reducing

the variance in the population. When there is weak negative epistasis—such that beneficial alleles have a less than multiplicative effect on fitness—recombination allows variance to persist and the population is more able to respond to changes in selection (Charlesworth 1993, Barton 1995, Barton and Otto 2005). Consistent with this expectation, sexually reproducing yeast populations had a higher fitness than otherwise identical asexual populations when both were evolved under strong selective pressure, but had the same fitness when evolved in benign environments (Goddard et al. 2005).

Population structure could play an important role in the adaptive benefits to recombination. Linkage disequilibrium can accumulate either by drift in small subpopulations or by local adaptation if subpopulations experience different selective pressures (Lenormand and Otto 2000). Gene flow between populations allows potentially adaptive alleles lost from one population by selection or drift to be regained if local selection pressures change (Martin et al. 2006, Szollosi et al. 2006). For this reason, selection for recombination may be stronger in a subdivided population than in a very large unstructured population or than a set of small, isolated populations (Martin et al. 2006).

The benefit of genetic variance to sexual populations depends on variation itself being advantageous. In organisms whose offspring compete for local resources, the greater variability of offspring from sexual reproduction may mean that they compete less with each other than with offspring that are identical (Bell 1982, Maynard Smith 1989). Fluctuating selection that changes epistatic interactions over

the course of a few generations could prolong selection for increased recombination by maintaining polymorphism in very large populations (Maynard Smith 1978) so long as changes in selection are not too severe (Charlesworth 1993). For example, the "Red Queen" hypothesis suggests that selective pressure can fluctuate over time as parasites or diseases adapt to a prevalent genotype, and the host population responds by evolving resistance (Van Valen 1973). Sexual populations able to generate variation between generations would be more likely to have offspring which could escape infection. Consistent with predictions of the Red Queen, more common asexual snail clones are more affected by parasites than rare clonal genotypes (Dybdahl and Lively 1998), and there are more sexual females than asexual where the frequency of infection is high (Jokela and Lively 1995). However, in many empirical cases, it is difficult to distinguish whether the advantage to sex is increased variance or the alternative—reduced mutation load.

Asexuals carry a higher mutation load than sexuals

Mutation load – the reduction in fitness due to deleterious mutations carried by a population – is expected to be higher in asexuals than in sexuals. There are two main forces posited to drive this expectation: the loss of the best fit class through genetic drift ("Muller's Ratchet", Muller 1964, Felsenstein 1974), and more efficient selection against deleterious mutations when there is recombination ("Kondrashov's Hatchet", Kondrashov 1982,1984,1988).

In small populations, genetic drift can cause the stochastic loss and fixation of alleles. In asexual populations, the loss of individuals with the fewest harmful

mutations can occur through drift. Since asexuals lack recombination between lineages, there is no way to reconstitute this best-fit class once it is lost; this is called Muller's Ratchet. In sexual populations, however, the best-fit class can often be regenerated through recombination. Both asexuals and sexuals are subject to deleterious mutation accumulation (or genetic deterioration), but an asexual population cannot lessen its mutation load through recombination and subsequent selection for individuals with the fewest deleterious mutations (Muller 1964). While Muller's Ratchet can be halted if compensatory mutations are common (Wagner and Gabriel 1990), the rate of back and compensatory mutations has been demonstrated empirically to be less than the rate of deleterious mutations, at least in experimental systems (e.g. Chao 1990). Thus, over time, deleterious mutations accumulate in asexual lineages. Synergistic epistasis slows Muller's Ratchet in large populations, assuming all mutations are equivalent, because each additional mutation has a greater deleterious effect than the last and selection will remove these mutation-laden individuals from the population (Kondrashov 1994). If mutations have a continuous distribution, the overall rate of fitness loss due to Muller's Ratchet will keep accumulating even if there is synergistic epistasis, because additional mutations can have smaller effects on fitness and may escape selection (Butcher 1995).

Mutation accumulation has been hypothesized to lead to "mutational meltdown": the mutation load reduces population size, increasing the stochastic chance of deleterious mutation fixation, which further reduces the population size, leading to the collapse and extinction of the asexual population (Lynch and Gabriel

1990, Gabriel et al. 1993, Lynch et al. 1993). Zeyl et al. (2001) demonstrated that reproducible extinction occurred in some severely bottlenecked mutational lines of yeast, and attributed this to mutational meltdown. This hypothesis assumes that the loss of the best fit mutation class by Muller's Ratchet is accompanied by the fixation of deleterious alleles. However, this is not necessarily the case in diploid asexuals, particularly if the population size is large and the degree of dominance is low (Charlesworth and Charlesworth 1997). Fixation of deleterious mutations is also unlikely to lead to extinction when some compensatory mutations are permitted, unless the population size is very small (Poon and Otto 2000).

Sexual lineages may more efficiently purge the population of deleterious mutations by bringing together mutations to make a least-fit class (the mutational deterministic hypothesis; Kondrashov 1982, 1984, 1988). In large populations, recombination is favored if there is synergistic epistasis between deleterious mutations (when mutations occurring together cause a greater reduction in fitness than expected based on each mutation alone). Empirical evidence for synergistic epistasis remains mixed (Elena and Lenski 1997, Jasnos and Korona 2007), and some models do not require epistasis between loci for recombination to spread. For example, in diploid eukaryotes, dominance creates mutational synergy within, rather than between, loci. When deleterious mutations are mostly recessive, the benefits of sex come from the production of homozygous offspring which can be more efficiently eliminated by selection (Chasnov 2000). When there is inbreeding within the population, the proportion of homozygotes produced is even further increased,

reducing the level of dominance required for sex to be beneficial in the absence of (between locus) epistasis (Agrawal and Chasnov 2001). Sexual selection could also reduce the mutation load in sexual populations without requiring epistasis, if most deleterious mutations are partially recessive and partially affect traits evaluated by females (Siller 2001) or if sexual selection causes deleterious mutations to be more deleterious in males than in females (Agrawal 2001).

There is some evidence for greater mutation load in asexual compared to sexual lineages. Bottlenecked viruses do accumulate deleterious mutations in the lab (e.g., Chao 1990, Escarmís et al. 1996), and when viruses recombine, the resulting hybrid populations are more fit than their non-recombinant parents (Chao et al. 1997). Comparisons between non-recombining organelle and recombining nuclear genomes within a species find that apparently deleterious mutations accumulate faster in mitochondrial genes than in nuclear genes (Lynch 1996, Lynch and Blanchard 1998). Comparisons of mutation load in asexual species versus sexual species have mixed results. The ratio of the rate of amino acid to silent substitution in mitochondrial protein-coding genes is higher in obligately asexual lineages than in sexual lineages of *Daphnia pulex*, suggesting that the loss of segregation between nuclear and organelle genomes subjects genes to selective interference from the entire nuclear genome (Paland and Lynch 2006, but see Butlin 2006). However, Mark Welch and Meselson (2001) compared substitution rates in the heat shock gene between obligately asexual bdelloid rotifers and sexually reproducing monogonant rotifers, and found somewhat equivocal results: only small differences between bdelloid and

monogonant substitution rates were found, suggesting that faster deleterious mutation accumulation does not occur in the anciently asexual bdelloids. Although the bdelloid rotifers have reproduced asexually for millions of years (Mark Welch et al. 2004), they are able to take up genetic material from their environment and incorporate it into their genome after periods of extreme desiccation (Gladyshev and Meselson 2008). Thus, asexual bdelloids may have persisted for millions of years because they have a mechanism for rare sex.

VARIATIONS IN REPRODUCTION MODES

Models which examine the maintenance of sexual and asexual reproduction primarily assume apomictic parthenogenesis: females clone themselves through development of an unfertilized egg without recombination or segregation. However, sexual and asexual reproduction are part of a continuum (Fig. 1.1). In some forms of clonal reproduction, behaviors associated with sex have been retained, and interactions between sexual and asexual species occur. These interactions may allow rare genetic exchange, which in turn could partially counteract the negative effects of long-term asexual reproduction (Pamilo et al. 1987, Green and Noakes 1995, Hurst and Peck 1996). How do the costs and benefits discussed above change in reproductive modes that mix aspects of asexual and sexual reproduction?

Gynogenesis

Gynogenesis is a form of asexual reproduction that retains many of the behavioral aspects of sexual reproduction (reviewed in vertebrates by Dawley 1989, Vrijenhoek 1994). Eggs of gynogenetic females require sperm from males of closely

related sexual species to activate embryogenesis, but males do not contribute genes to offspring (Fig. 1.1C). Gynogenetic females could therefore be considered parasites of sexual species (Hubbs 1964). Reasons for the stable persistence of both gynogenetic and host species in the same geographic location is the subject of some debate (e.g., Dries 2000), since gynogenesis requires the presence of sexual males, and yet these parasitized males gain no immediate fitness advantage by mating with gynogens.

In the Amazon mollies (*Poecilia formosa*), microchromosomes are passed on from host males, and these microchromosomes contain genes with effects on phenotype (Schartl et al. 1995a, Lamatsch et al. 2004). Some microchromosomes are inherited by subsequent generations of female clones (Schartl et al. 1995a, Nanda et al. 2007). These microchromosomes may compensate for mutational load by providing novel beneficial alleles or genetic material that masks deleterious mutations (Schartl et al. 1995a). Rarely, chromosomes of haploid sperm are integrated with the diploid maternal genome, causing triploid, gynogenetic offspring (Schlupp et al. 1998), although triploidy is unstable and individuals can end up with both diploid and triploid somatic cells (Lamatsch et al. 2002). Thus, gynogenetic lineages which gain genetic material from males may persist for longer periods of time than expected under Muller's Ratchet (Loewe and Lamatsch 2008). However, in the absence of recombination, deleterious mutations would not be as efficiently purged by selection, and still accumulate in the genome.

Hybridogenesis and kleptogenesis

Hybridogenetic females also require males of another species, but unlike gynogenetic females, paternal DNA is incorporated into and is expressed in offspring. Gametes, however, do not contain this paternal DNA, but only DNA from the maternal line (Fig. 1.1D). Hybridogenetic females can be considered parasites on sexual species, since only the female genome is transmitted to subsequent generations (Vrijenhoek 1994). Offspring are variable, so some of the adaptive advantages of sexual reproduction are retained. However, mutations are expected to accumulate in the female clonal genome due to drift (Nei 1970), and empirical evidence in both fish and frogs suggests that these genomes are experiencing mutational decay (reviewed in Vrijenhoek 1994). If most deleterious mutations are highly recessive, then chromosomes from sexual males could shelter the clonal genome and allow persistence of hybridogenetic lineages despite mutation accumulation, as long as stable coexistence of sexual and hybridogenetic lineages continues.

Kleptogenesis is a form of reproduction which shares some similarities with hybridogenesis and gynogenesis, in that females require sperm to initiate reproduction and produce all-female offspring. Females maintain ploidy by premeiotic chromosomal duplication, and after fertilization offspring either inherit only the maternal DNA or also inherit paternal chromosomes, which can replace or add to the existing genome (Bogart et al. 2007). Kleptogenesis is currently only known in a species complex of polyploid salamanders in the genus *Ambystoma* (Bogart et al. 2007, Mable 2007). These females contain at least one haploid

chromosome set from *A. laterale* (Hedges et al. 1992), but have varying copy numbers of nuclear genomes from other, closely related sexual species, and are nested within *A. barbouri* on a mitochondrial phylogeny (Bogart et al. 2007). This suggests that kleptogenetic females arose through an ancient hybridization event between an *A. laterale* male and an *A. barbouri*-like female (Bogart et al. 2007). As they moved into sympatry with sexual species, these females stole and swapped out genomes, such that the *A. barbouri* nuclear genome has been lost (Bogart et al. 2007). This strange combination of partially clonal, partially sexual reproduction may have allowed kleptogenesis to persist over millions of years (Bogart et al. 2007).

Androgenesis

Androgenesis occurs when offspring carry nuclear chromosomes from only the male parent. I define three types of androgenesis:

(1) *artificial androgenesis*: gametes are manipulated in the lab to produce offspring with only paternal nuclear genes (e.g., Hasimoto 1934, Surani et al. 1984, Datta 2005, Grunina et al. 2005, Rapacz et al. 2005, Brown et al. 2006). Artificial androgenesis by definition does not occur in nature and therefore I will not discuss it further.

(2) *facultative androgenesis*: offspring with only paternal nuclear DNA are rarely produced from parents who normally reproduce sexually. Facultative androgenesis has been observed between crosses of several different plant lineages (Campos and Morgan 1958, Goodsell 1961, Burk 1962, Chase 1963, Abdalla and Hermsen 1972, Chen and Heneen 1989, Horlow et al. 1993, Pelletier et al. 1987),

albeit at low frequency (between 10^{-2} and 10^{-6} ; Chen and Heneen 1989 and references therein). In animals, facultative androgenesis has been detected in both lab stocks of fruit flies (Komma and Endow 1995) and in hybrid complexes of stick insects (Mantovani and Scali 1992). The frequency of facultative androgenesis in natural systems is difficult to determine, but it is reasonable to assume that it can and does occur, at least rarely.

(3) *obligate androgenesis*: all offspring inherit only paternal nuclear DNA (Fig. 1.1E). Only a few divergent eukaryotic lineages appear to reproduce obligately through androgenesis: the Saharan (or Tassili) cypress tree, *Cupressus dupreziana* (Pichot et al. 2001), haploid drone lineages of the little fire ant, *Wasmannia auropunctata* (although workers contain both maternal and paternal DNA; Fournier et al. 2005), and four species in the clam genus *Corbicula*: *C. leana* (Komaru et al. 1998), *C. fluminea* (Ishibashi et al. 2003), *C. australis* (Byrne et al. 2000), and *C. fluminalis* (Korniushin 2004). Androgenesis has been identified as the main form of reproduction in very few species in part because androgenesis can lead to population extinction, particularly in dioecious species (McKone and Halpern 2003), and in part because androgenesis is difficult to detect without genetic analysis. For the remainder of this chapter and for the next two chapters (Chapters 1-3), when I use the term androgenesis, I am referring to obligate androgenesis. I will discuss facultative androgenesis further in Chapter 4 and there will use explicit terminology to distinguish between types of androgenesis.

Androgenesis may not be as difficult to evolve as it would intuitively seem. In animals, the initial axis of orientation of the maternal nuclear genome in both meiosis I and meiosis II is parallel to the cell cortex (Karpen and Endow 1998). In normal meiosis, this axis of meiosis is reoriented at fertilization so that it is perpendicular to the cell cortex, which allows the production of one polar body with each meiotic division. The meiotic product that is adjacent to the cell cortex is expelled as a polar body. A knock-out mutation in the signaling pathway for axis reorientation would cause complete extrusion of the maternal genome (e.g., see Gard et al. 1995). In species intolerant to haploidy, evolution of unreduced sperm (as in *Corbicula*; Komaru and Konishi 1999) or chromosomal doubling after fertilization (as in *Drosophila*; Komma and Endow 1995) would restore normal ploidy.

Androgenetic males parasitize maternal resources—eggs and/or nutrition during development—to produce offspring that do not incorporate maternal DNA. This gives a substantial fitness advantage to the androgenetic individual over sexual conspecifics, and will lead to the rapid spread of androgenesis within a population under most simulation conditions (McKone and Halpern 2003). However, the maintenance of androgenesis after fixation is hard to explain, since most simulated scenarios lead to population extinction, particularly in species with two separate sexes (McKone and Halpern 2003). Extinction probabilities are reduced in hermaphrodite species, because paternal clones can produce both sperm and eggs (McKone and Halpern 2003).

Androgenetic pollen of the Saharan cypress can steal the ovules of a closely related congener to propagate its own clonal offspring (Pichot et al. 2001). This suggests that in some systems, androgenetic individuals may not only have an advantage over sexually-reproducing members of their own species, but over closely-related species as well. The potential for egg-stealing implies there may be an advantage not only to androgenetic over sexually-reproducing members within a population (as discussed in McKone and Halpern 2003), but that androgenetic species may additionally benefit by being able to steal eggs from other, closely related species.

Obligately androgenetic species may benefit from rare capture of genetic material from other species. As mentioned above, gynogenetic fish can inherit chromosomal material from parasitized males of another species (Schartl et al. 1995a, Lamatsch et al. 2004). In the little fire ant, rare sexual reproduction between divergent androgenetic drones and parthenogenetic queens produced reproductives with hybrid genotypes (while sterile workers always share genes from both clonal lineages; Foucoud et al. 2006). If androgenetic species have the ability to steal the eggs of other species, they may rarely incorporate novel genetic material from the maternal species. This in turn increases expectations for the long term persistence of androgenesis, as that novel material may provide adaptive variation or mask deleterious mutations.

STUDY SYSTEM: CLAMS IN THE GENUS *CORBICULA*

Clams in the genus *Corbicula* are native to fresh and brackish waters in Asia, Africa, the Middle East, and Australia, and in the past century have invaded

freshwater rivers in the Americas and Europe (reviewed in McMahon 1982). The genus contains sexually reproducing species with two separate sexes (Okamoto and Arimoto 1986, Glaubrecht et al. 2003) and hermaphrodites, at least some of which reproduce through androgenesis (Komaru et al. 1998, 2000, Komaru and Konishi 1999, Byrne et al. 2000, Ishibashi et al. 2003, Korniusshin 2004). Accounting for species diversity in *Corbicula* is complicated by different historical approaches to taxonomy: for example, early researchers mistakenly classified juveniles as separate species from adults (Prashad 1933), while other researchers have argued for classifying all fresh-water *Corbicula* as one species (Morton 1986) despite morphological, genetic, and cytological evidence to the contrary (e.g., Hillis and Patton 1982, Okamoto and Arimoto 1986, Glaubrecht et al. 2003). Therefore, classification of *Corbicula* is an on-going process, but there is good evidence for at least four morphologically distinct androgenetic species in East Asia, Africa, and Australia (Komaru et al. 1998, Byrne et al. 2000, Ishibashi et al. 2003, Korniusshin 2004), and for at least eight sexual species in Japan, China, and Indonesia (Glaubrecht et al. 2003, Korniusshin and Glaubrecht 2003, Korniusshin 2004), with additional sexual and/or asexual species in Africa and other parts of Asia, where *Corbicula* taxonomy has not been carefully re-examined.

The mechanism of androgenetic reproduction is well characterized in *Corbicula*. After fertilization by an unreduced biflagellate sperm (i.e., nuclear DNA content is equal to somatic cells; Komaru et al. 1997, Komaru and Konishi 1999), the oocyte ejects the entire maternal nuclear genome as two polar bodies (Komaru et al.

1998, Komaru et al. 2000, Ishibashi et al. 2003). Developing embryos are brooded within the hermaphrodite mother's gills, where they probably receive nutritional benefits (Kraemer et al. 1986). Embryos are found within the gametogenic follicles before gamete release, suggesting that self-fertilization is a common mode of reproduction (Kraemer 1978). However, mucosal strands containing sperm have been observed connecting siphons of two androgenetic clams, suggesting that outcrossing is also likely (Kraemer et al. 1986). If androgenetic sperm can successfully steal the eggs of another individual, then androgenesis could confer a substantial fitness benefit compared to sexually reproducing individuals in *Corbicula*, assuming all else is equal (McKone and Halpern 2003).

I ask three questions about *Corbicula*:

(1) Can androgenetic *Corbicula* steal eggs of closely-related species to produce paternal clones? (Chapter 2)

(2) Do offspring of androgenetic *Corbicula* inherit nuclear DNA from other species? (Chapters 2 and 3)

(3) What is the origin of androgenetic species diversity in *Corbicula*? (Chapter 3)

The answers will affect my expectations for the long-term persistence of androgenesis in the genus. If *Corbicula* can fertilize the eggs of another species, mitochondrial markers would be shared between species where they are sympatric, but unique where they are allopatric. The ability to parasitize another species would suggest an additional fitness benefit to androgenesis where species ranges overlap. If

nuclear gene exchange regularly occurs between species, nuclear markers would be shared in sympatry but not in allopatry; this would suggest that androgenesis in *Corbicula* is not truly an obligately asexual means of reproduction since maternal DNA is regularly inherited. However, if nuclear gene exchange occurs only rarely, nuclear markers in sympatry would not be shared, but phylogenetic analyses across the genus would find divergent alleles within a single androgenetic lineage. There are other possible causes for within-individual allelic divergence, and correct interpretation of divergence depends on simultaneous consideration of the possible origins of androgenesis. For example, a hybrid origin could also cause divergent alleles to be found in an individual clam.

Based on phylogenetic research on other asexual systems, androgenesis could have a single ancient origin with subsequent diversification of species, there could be independent, recent origins due to repeated mutations or hybridization, or there could have been a single recent origin with subsequent genetic capture from related species. Each of these hypotheses generates different phylogenetic expectations about the relationships between sexual and asexual species in phylogenies derived from mitochondrial markers (which are maternally inherited) and nuclear markers (which may contain both maternal and paternal DNA; Figure 1.2).

Single origin. A single androgenetic lineage could accumulate morphological and genetic distinctiveness through mutation and selection over time, resulting in speciation of multiple asexuals (Barraclough et al. 2003, Birky et al. 2005, Fontaneto et al. 2007, Hillis 2007). If there is a single origin of androgenesis in *Corbicula*,

followed by species divergence from a single common androgenetic ancestor, androgenetic species would be monophyletic on both mitochondrial and nuclear gene trees (Figure 1.2A). If androgenetic *Corbicula* lack segregation and recombination, each allele present in the ancestral asexual would be retained through subsequent generations (Birky 1996, Normark et al. 2003). Alleles would accumulate mutations independently and diverge in nucleotide sequence (Judson and Normark 1996, Birky 1996) and possibly even diverge in function (Pouchkina-Stantcheva et al. 2007).

There are lineages which have reproduced asexually for millions of years and have diversified into morphologically and ecologically distinct species (reviewed in Maynard Smith 1978, Judson and Normark 1996, Normark et al. 2003). Since theory leads us to expect asexuals will go extinct over such a long period of time, the existence of these ancient asexuals requires explanation. There are a number of largely untested hypotheses as to why ancient asexuals have escaped extinction, including: an enhanced DNA repair system (Drake 1991), lack of efficient repair leading to strong selection against damaged individuals (Gabriel et al. 1993), high fidelity polymerase and low metabolic rate decreasing the base mutation rate (Mindell and Thacker 1996), and recombination between homologous chromosomes during gamete formation or somatic recombination during mitosis creating homozygosity for deleterious mutations (Little and Hebert 1996, Butlin et al. 1998). However, a reasonable explanation for the persistence of these lineages is that rare sex occurs (e.g. Hurst and Peck 1996, Little and Hebert 1996). Genetic evidence that some parthenogenetic lineages have engaged, rarely, in sex is accumulating (Crease and

Lynch 1991, Normark 1999), either with males of other species or when males are produced mitotically by asexual mothers (e.g., Butlin et al. 1998), or by the uptake of genetic material from the environment (Gladyshev and Meselson 2008).

If androgenetic *Corbicula* have rarely incorporated genetic material from other species, this could be detectable on a phylogenetic tree if the species were sufficiently diverged. On a phylogenetic tree, the nuclear alleles associated with paternal, androgenetic chromosomes would group as monophyletic, since they came from the same androgenetic ancestor. However, the captured nuclear alleles from the maternal species would be found on a separate branch of the tree (Fig. 1.2C). Nuclear genetic capture could occur through polyploidization. A diploid, androgenetic *C. fluminea* individual did have triploid offspring in the lab, presumably because the egg's spindle fibers lined up correctly during meiosis, allowing a haploid set of maternal chromosomes to be inherited along with the diploid set of paternal chromosomes (Komaru et al. 2006). Variation in ploidy is also found in natural populations of *C. fluminea*, ranging from diploid to tetraploid (Okamoto and Arimoto 1986, Qiu et al. 2001).

Hybrid origins. Hybridization between two sexually reproducing species could cause androgenesis, if the interaction between the two genomes disrupted sexual reproductive behavior. If androgenesis in *Corbicula* were due to hybridization, nuclear alleles from androgenetic clams would be split on the gene tree, such that each allele would group with its contributing parental species (Fig. 1.2A,B). Assuming no recombination and segregation of the genome, the hybridization event

would be detectable on each gene tree, since both parental alleles would be maintained over time (Birky 1996). If there is segregation during gametogenesis ("automixis"), one of the two alleles would be lost over time, but androgenetic alleles would always group with one or the other parental species across gene trees.

Parthenogenetic, gynogenetic, hybridogenetic, and androgenetic reproduction all have examples of hybridization at their origin, often associated with polyploidization (e.g. parthenogenetic lizards and snails: Moritz and Heideman 1993, Johnson and Bragg 1999; gynogenetic fish and snails: Vrijenhoek 1994, Ó Foighil and Smith 1995; hybridogenetic stick insects and fish: Mantovani and Scali 1992, Schartl et al. 1995b). Gynogenetic vertebrates have so far all been found to have hybrid origins (Dawley 1989, Vrijenhoek 1994), with the consequence that gynogenetic females can attract and parasitize males from both parental species (Dries 2003). Androgenesis has also arisen as a consequence of hybridization in the stick insect complex *Bacillus rossius-grandii benazzii* (Mantovani and Scali 1992), although androgenesis is facultative and not obligate in this system. Hybridization may lead to asexuality when the hybridizing species are different enough to deregulate genetic control of meiosis in the hybrid, but not so different that development and fertility are affected (Vrijenhoek 1994).

Repeated origins. If androgenetic *Corbicula* have arisen multiple times from sexual species over the course of their history, phylogenetic analysis may be able to distinguish independent origins (Fig. 1.2B). In some species, mutations which lead to asexual reproduction appear fairly easy to evolve, and asexual species are relatively

frequently generated. Phylogenetic analyses of these species groups tend to show asexual lineages on short branches nested within a sexual species (e.g., *Eucypris virens*: Butlin et al. 1998, *Campelema*: Johnson and Bragg 1999, *Daphnia pulex*: Paland et al. 2005). While each individual asexual lineage may be short-lived, asexuals may still have co-existed with sexual species for long periods of time. For example, some water fleas (*Daphnia pulex*) have evolved parthenogenesis in multiple lineages (Innes and Hebert 1988, Paland et al. 2005). In this species, the evolution of parthenogenesis only requires a single knock-out mutation in the gene for meiosis in the female, making all offspring apomictic clones of the mother (Innes and Hebert 1988). In this group, asexual reproduction can be “contagious”, because functional males which mate with sexual females can transmit female-limited meiotic suppressors to their offspring (Paland et al. 2005). Alternatively, if hybridization between sexual species causes asexuality, independent hybridization events between species whose ranges overlap could cause multiple, diverse clonal lineages to form (e.g., parthenogenetic lizards: Moritz 1983, hybridogenetic fish: Quattro et al. 1991). From a practical standpoint, it may be difficult to distinguish a single, hybrid origin with subsequent diversification from multiple independent, hybrid origins (Fig. 1.2A,B).

IMPLICATIONS OF RESEARCH ON *CORBICULA*

Evolutionary biologists debate about which evolutionary forces drove the initial evolution of sexual reproduction in eukaryotes, and how important these forces are for its subsequent maintenance. Understanding asexuality is critical to solving the

question of the evolution and maintenance of sex. This research will increase our understanding of 1) the selective advantages of asexual reproduction, and 2) the forces which can cause a shift from sexual to asexual reproduction. Alleles for androgenesis are selfish genetic elements which could serve as a mechanism for their own spread within a population. If androgenesis allows one species to use the eggs of another, it could facilitate the invasion of one species into habitat already occupied by the other. Androgenetic species could avoid the pitfall of excessive mutational load if mutations in the asexual genome are sheltered by chromosomes gained from rare hybridization events with sexual species. Androgenesis could thus be maintained over the long term compared to other asexual mating systems.

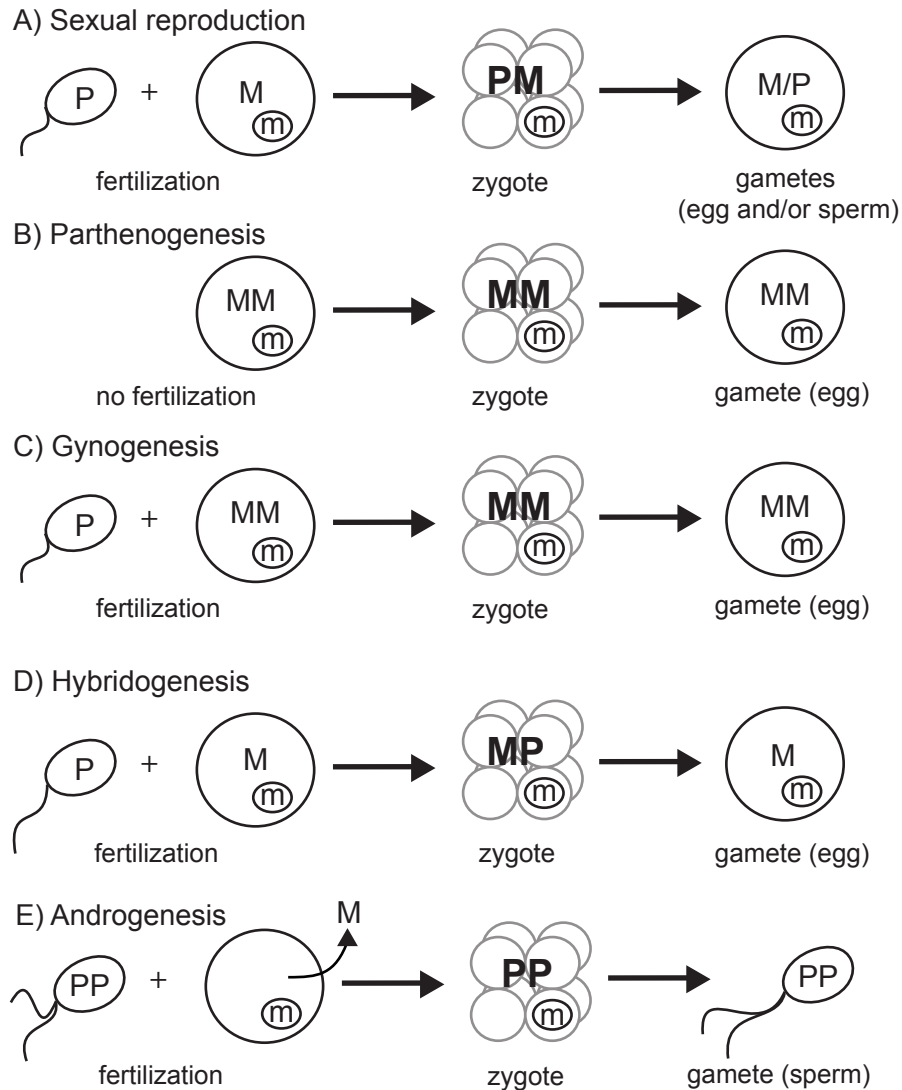

Figure 1.1 Some modes of reproduction. P: paternal haploid chromosome set; M: maternal haploid chromosome set; m: maternal mitochondrial genome. A) Typical sexual reproduction: haploid chromosomes from each parent form the genome of the zygote. Gametes produced by the next generation are haploid but contain genes from both parents. B) Parthenogenesis: division of an unreduced egg produces female offspring. C) Gynogenesis: sperm are required to activate embryogenesis in an unreduced egg; offspring are female and inherit only maternal DNA. D) Hybridogenesis: nuclear DNA from the father is incorporated into offspring, but only maternal DNA is found in gametes and inherited through multiple generations. E) Androgenesis: only nuclear chromosomes from the father's sperm are passed on to offspring, but mitochondria can be inherited from the mother. Androgenesis can occur with either haploid or unreduced sperm.

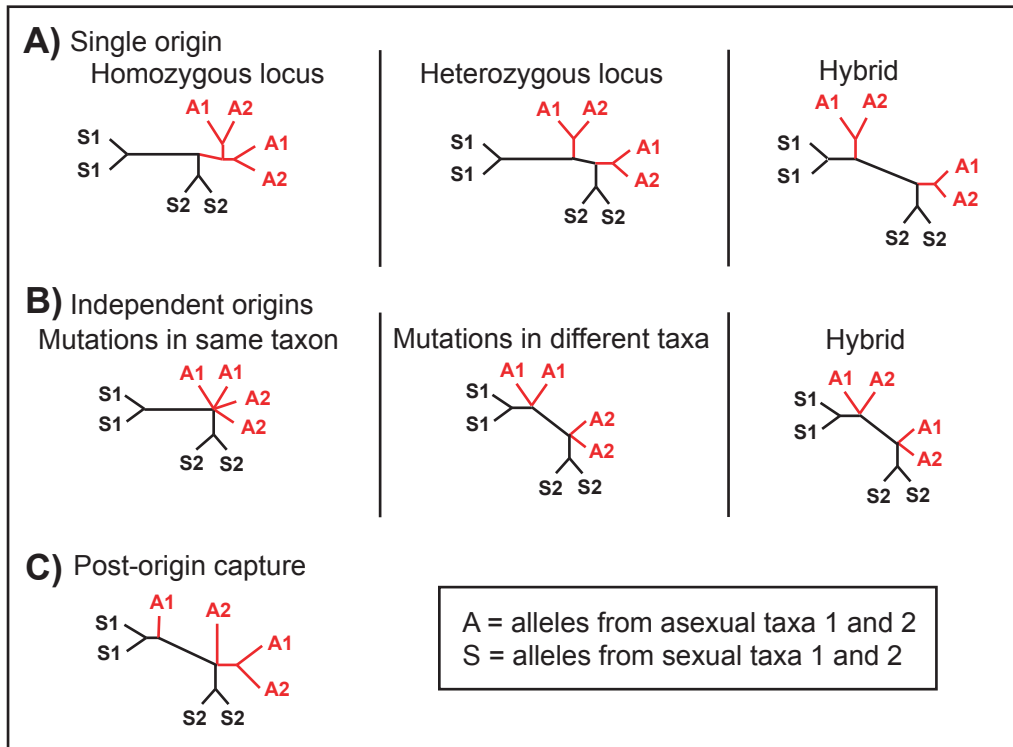

Figure 1.2 Relationships between nuclear alleles is dependent on origin of asexuality. Trees assume alleles are maintained over time in asexuals, but converge in sexuals through segregation and recombination. Species are diploid and there are two alleles per species. Asexual lineages are in red, sexual are in black. A-C) Single origin of asexual reproduction from sexual species S2; the clonal lineage speciates. Relationships between alleles depend on whether a locus is initially homo- or heterozygous, or whether the asexual is a hybrid between two sexuals. D-F) Multiple independent origins of asexual reproduction. E) The asexual lineage A1 acquires DNA from S1 in a rare genetic capture event.

Chapter 2: Implications for Androgenesis from *Corbicula* in the Americas

Since their first known appearance on Vancouver Island in British Columbia in 1924 (Counts 1981), invasive clams in the genus *Corbicula* have spread throughout the United States, where they can reach densities of well over 2000 individuals per square meter (McMahon 1999). Its North American distribution seems primarily limited by winter freezing in the north (Counts 1986). Although the precise effects on native fauna and flora have not been determined, at a minimum *Corbicula* prevents recolonization of disturbed areas by native endangered unionid mollusks (Fuller and Imlay 1976) and can reduce algal density in rivers (Cohen et al. 1984). *Corbicula* are also a significant biofouling nuisance species for industry (for review, see Isom 1986).

Three morphologically distinct species of *Corbicula* have invaded the Americas, and all have the biflagellate sperm recognized as a diagnostic marker of androgenesis (Konishi et al. 1998, Byrne et al. 2000, Lee et al. 2005). Clonal reproduction is further supported by little or no genetic variation within populations, as documented by both allozyme loci (Smith et al. 1979, Hillis and Patton 1982, McLeod 1986) and mitochondrial and nuclear DNA sequences (Siripattawan et al. 2000, Lee et al. 2005, this study). The two North American species (“form A” and “form B” of Britton and Morton 1979, or the “white morph” and “purple morph” of Hillis and Patton 1982) have significantly different shell morphologies

(“morphotypes”; Hillis and Patton 1982), are fixed for different allozyme loci (Hillis and Patton 1982), and have unique mitochondrial DNA sequences associated with each species (Siripattrawan et al. 2000, Lee et al. 2005). They are easily distinguishable in the field based on color and shape of exterior shell. However, there is presently no consensus on the exact species identification for any of the invasive *Corbicula*. I will refer to the North American species as form A and form B.

There is some evidence that androgenetic *Corbicula* may have the ability to steal the eggs of closely related species to produce their own clonal offspring. In the Río Grande, where form A and form B *Corbicula* are sympatric (found in the same location), form B mitochondrial sequence has been found in clams which have the morphological features of form A (Lee et al. 2005). This could be explained by either hybridization between species (sexual reproduction between two species such that offspring inherit chromosomes from both parents), or by mitochondrial genome capture after egg-stealing of a form B egg by form A. The nuclear chromosomes of the maternal species would have been ejected from the egg, leaving paternal nuclear chromosomes and the maternal mitochondria (as in Fig. 1.1C). However, current evidence for hybridization is somewhat contradictory: McLeod (1986) observed several polymorphic allozyme loci in a population of form B where it was found with form A, and suggested that nuclear gene exchange between forms A and B was a possible explanation. In contrast, Hillis and Patton (1982) found no evidence for gene exchange where populations of forms A and B were found together, as the allozyme loci they examined were completely fixed and diagnostic between the two species,

and they observed no clams with intermediate morphologies. Furthermore, Lee and coworkers analyzed DNA sequences of the large ribosomal subunit (28S) gene from fifteen individuals of each morphotype at one locality, but found no evidence of shared alleles, as would be expected if these species were regularly hybridizing (Lee et al. 2005). However, the very limited number of sympatric populations used in these previous studies of North American *Corbicula* leaves open the possibility of gene exchange between the species.

I collected data on mitochondrial and/or nuclear genes from 23 localities of *Corbicula* (including 10 sympatric localities for forms A and B) to test for either nuclear recombination or egg-stealing between the two species. If androgenesis does not serve as a barrier to frequent nuclear genetic exchange, I predict that nuclear markers will be shared between the two species. Alternatively, if there is mitochondrial genome capture in the absence of nuclear recombination, I expect nuclear markers to be diagnostic between species, whereas some mitochondrial genomes will be shared. Finally, I built a mitochondrial phylogeny using mitochondrial sequences from across the global range of *Corbicula* to test whether the observed androgenetic species diversity within the Americas is the result of diversification from a common androgenetic ancestor, or whether mitochondrial lineages represent separate evolutionary lineages.

METHODS

Sample collection

Clams were collected from 23 localities in Argentina, Korea, Mexico, the Netherlands, and the United States (Table 2.1). Forms A and B were classified in the field by exterior shell morphology. Ten of these localities included sympatric populations of forms A and B, 11 localities had allopatric populations of form A only, one locality included sympatric populations of forms A and C (a third species introduced into South America), and one locality had the sexual species *C. japonica* only. Specimens from Argentina were obtained from C. Ituarte; specimens from the River Waal and the River Lek in the Netherlands were obtained from A. de Vaate; specimens from Georgia, U.S.A. were obtained from J. Williams and R. Butler; and specimens from Arizona, U.S.A. were obtained from M. Sredl. Ethanol-preserved specimens of *C. japonica* from a Korean fish market were obtained from J. Bickham, and the original locality for these specimens is unknown. DNA for sequencing was extracted from tissues using Qiagen DNeasy tissue extraction kit (Qiagen Inc., Hilden, Germany); DNA for restriction site analysis was extracted using protocol 1 from Hillis et al. (1996). In most cases tissue was taken from the foot or main body of the clam; for one form B sample from the Colorado River I used gonadal tissue.

Restriction site analysis

To examine the possibility of hybridization events between the various putative species of *Corbicula*, restriction digest of the nuclear ribosomal RNA gene regions (rDNA arrays) from 17 populations (165 individuals) of form A and seven populations (70 individuals) of form B were performed (Table 2.1). These samples represent populations introduced throughout the United States, as well as into

Argentina, the Netherlands, and Mexico, and included seven localities where forms A and B are sympatric. Specimens were individually digested with five restriction enzymes: *Eco* RI (recognition sequence: G/AATTC), *Bgl* II (A/GATCT), *Bst* EII (G/GTNACC), *Nco* I (C/CATGG), and *Pvu* II (CAG/CTG). Restriction maps of rDNA arrays were obtained by double-digestion with pairs of restriction enzymes, using the conserved *Eco* RI restriction sites in the 18S and 28S genes as reference sites (Figs. 2.1 and 2.2). Restriction fragments were separated on 0.8% agarose gels (5 V/cm for 15 hours), along with a one kb-plus ladder as a size standard. DNA was transferred to nylon membranes using the protocol of Southern (1975). Southern blots were then probed using either a series of radioactively labeled oligonucleotides that were located on each side of the conserved *Eco* RI reference sites (primers 28aa, 28w, 18d, and 18e of Hillis and Dixon 1991), or (for the single digests) radioactively labeled clones of the 18S and 28S genes (pI19 and p2546; Arnheim 1979).

In-situ hybridization

To examine possible polyploidy or other chromosomal anomalies, *in-situ* hybridization of the NOR regions was performed on 3 individuals of each form from Georgetown, San Gabriel River, Texas, USA (Table 2.1). The pI19 rDNA fragment cloned and described by Arnheim (1979) was used as a probe. The plasmid was biotin-labeled, and *in-situ* hybridization followed the procedure described by Moyzis et al. (1987). Twenty-five cells were examined per form.

Gene amplification and sequencing

To examine nuclear sequence diversity at a finer scale than the restriction digests, I amplified and sequenced the first internal transcribed spacer (ITS-1) and a portion of the large ribosomal subunit (28S) of nuclear rDNA from four sympatric populations (Table 2.1). I used universal primers 18dd and 5.8S (Hillis and Dixon 1991) to get an initial ITS-1 sequence. As portions of the 5.8S ribosomal gene appear to have been duplicated and reversed within the internal transcribed spacer regions, I designed an alternative, bivalve-specific primer using sequences from scallops and unionids (GenBank accession nos. AY294561, AY319383-5, AY313964, AJ534981, AJ428407-9), 5.8Ssh3: 5'ATTCACATTAATTCACGCACCTG3'. To amplify within the 28S gene, I used primers D23F and D4RB (Lee et al. 2005). Reaction conditions were: 2.5 µl Thermopol 10X buffer with MgCl₂ (NEB), 2.5 µl 25 mM dNTPs, 0.75 µl each 10 mM primer, 0.2 µl NEB *Taq* polymerase, and 1-3 ul DNA extract, brought to a total volume of 25 µl with double-distilled water. PCR conditions were 94°C 1:30 min, 35 cycles 94°C 1 min 60°C (ITS-1)/55°C (28S) 1 min 72°C 2 min, 72°C 5 min. To sequence individual alleles, I cloned PCR products using the Invitrogen TOPO TA Cloning[®] kit with pCR[®] 2.1-TOPO[®] vector (Invitrogen Life Technologies, Grand Island, NY, USA). For PCR of clones I used the reaction conditions and primers provided by the kit. I sequenced between six and eight clones per individual to examine within-individual variation in the rDNA arrays (Table 2.1). These sequences

were deposited into GenBank (accession nos ITS-1: EU090360-95; 28S: EU090400-29).

To compare nuclear and mitochondrial diversity within North American *Corbicula*, I used primers HCO and LCO (Folmer et al. 1994) to amplify a 710 bp fragment of COI for 261 clams from 14 sampling locations (Table 2.1) under the following PCR conditions: 1 μ l DNA extract, 1.5 μ l 10X buffer without MgCl₂, 1.5 μ l 25 mM dNTPs, 1 μ l 25 mM MgCl₂, 1 μ l each 10 mM primer, 1 μ l *Taq* polymerase, brought to a volume of 25 μ l with double-distilled water. PCR cycles were run on an Applied Biosystems Gene Amp 2700 thermocycler, with an initial starting temperature of 94°C for 1 min. 30 sec., followed by 35 cycles of 94°C 1 min., 46°C 1 min., 72°C 2 min., and a final extension of 72°C 7 min. Sequences were run on either an Applied Biosystems 377 or an Applied Biosystems 3100 automated sequencer. Four Korean sequences representing two haplotypes were deposited into GenBank (accession nos. EU90396-9). All of my American and European mitochondrial sequences matched existing GenBank sequences from previous studies on *Corbicula* (Table 2.2; haplotypes H1, H2, and H4).

Phylogenetic analyses: nuclear phylogenies

To explore evidence for nuclear genetic exchange between North American *Corbicula* species, I inferred phylogenies of both ITS-1 and 28S sequences. Previously published 28S sequences for both North American invasive *Corbicula* (forms A and B) and the South American species (form C) were obtained from

GenBank (AF519526-8) and added to my data set. Sequences were similar enough that there were relatively few areas of alignment ambiguity, so all sequences were aligned by hand using MacClade 4.06 (Maddison and Maddison 2000). Alignments are available on the TreeBase website, (<http://www.treebase.org>, study accession no. S1894). Ends were trimmed to reduce the amount of missing data. In the ITS-1 alignment, all gaps, including a 161-bp indel found in three sequences, and any regions not easily aligned were removed before phylogenetic analyses (278 bp total removed, 590 bp remaining). I determined the best-fit model of evolution using the Bayesian information criterion (BIC) implemented in the program ModelTest v3.7 (Posada and Crandall 1998). I determined the maximum likelihood estimate of the phylogeny using GARLIv0.952b2.r171 (Zwickl 2006). The default settings were used for all searches. I performed Bayesian analyses using MrBayes v. 3.1.2 (Ronquist and Huelsenbeck 2003). I ran four independent MCMC analyses (each using four chains) for five million generations, and trees and parameters were sampled every 100 generations. I used MrConverge (as described in Brown and Lemmon 2007: <http://www.evotutor.org/MrConverge/>) to determine when convergence between runs had been reached, the posterior probability of bipartitions, and the post burn-in Bayesian consensus tree with branch lengths.

Phylogenetic analyses: mitochondrial phylogeny

To place the North American mitochondrial sequences into the historical context of the genus *Corbicula*, I constructed a molecular phylogeny of *Corbicula* clams using mitochondrial cytochrome oxidase I (COI) sequences, incorporating

GenBank data from previous studies into my data set (Table 2.2). Sequences were aligned manually using MacClade 4.06 (Maddison and Maddison 2000) and trimmed to 584 base pairs to minimize missing data at either end of the sequence. For analysis, each haplotype was given a number, with identical sequences collapsed to one haplotype (Table 2.2). Alignment is available on the TreeBase website (<http://www.treebase.org>, study accession no. S1894). The program ModelTest v.3.7 (Posada and Crandall 1998) was used to determine the appropriate model of evolution under the Akaike criterion. The program GARLI (Zwickl 2006) was used to find the maximum likelihood estimate (MLE) of the phylogeny. The default settings were used for all searches. I selected bivalves *Neocorbicula limosa* and *Polymesoda caroliniana* to root the tree (following Glaubrecht et al. 2003). The Bayesian consensus topology was obtained as described above for ITS-1 and 28S.

I evaluated hypotheses on the maximum number of independent androgenetic lineages by comparing the Bayesian posterior probabilities of alternative tree topologies. These posterior probabilities were determined by filtering post burn-in trees which matched a given topology (a backbone constraint tree) using PAUP* v.4b (Swofford 2002), and dividing the number of trees sampled consistent with that topology by the total number of sampled trees. I filtered topologies using a series of backbone constraints (Table 2.4), allowing for different modes of reproduction in some of the unstudied taxa. I tested the monophyly of androgenetic taxa with respect to known sexual taxa (Table 2.2: androgenetic haplotypes H1, H2, H4, and H56), which is the expectation if androgenesis had evolved once with no reversions to

sexuality. To test support for two independent clades of androgenetic *Corbicula*, I filtered the Bayesian post-burn-in tree sample for all possible combinations of two clades of androgenetic taxa (Table 2.4), and then filtered those trees to remove any that were also consistent with complete monophyly (i.e., that would place the two clades as sister taxa). Finally, I tested for support for three separate clades of androgenetic taxa, again using successive filters to remove trees consistent with both of the other two hypotheses.

I ran parametric bootstrapping (Swofford et al. 1996) to test whether there was a significant difference in likelihood score between the MLE and trees in which the four androgenetic taxa were constrained to be monophyletic, or trees in which androgenetic haplotypes H1, H4, and H56 were constrained to be monophyletic with respect to sexual taxa and androgenetic haplotype H2. One hundred replicate datasets were simulated using Seq-Gen v.1.2.5 (Rambaut and Grassly 1997) and all ML analyses were run in GARLI using the same search settings as for the MLE.

I tested for possible effects of long-branch attraction between the outgroups and the closest in-group – the clade containing brackish water, sexually reproducing *C. japonica* – by removing the outgroup and re-running Bayesian and ML analyses. Finally, I tested for long-branch attraction between the *C. japonica* clade and the fresh-water taxon *C. madagascariensis* by removing all taxa in the well-supported *C. japonica* clade and again running both Bayesian and ML analyses.

RESULTS

Diversity of ribosomal RNA arrays

Restriction-site maps of the nuclear ribosomal DNA repeats (rDNA arrays) for each form are shown in Figure 2.2. Across 140 individuals (70 form A, 70 form B) from seven sympatric North American localities (Table 2.1), both species of *Corbicula* are fixed for mutually diagnostic sets of rDNA arrays (Fig. 2.2). Each individual within a species shares a set of restriction sites and rDNA length variants (to the level of resolution of the restriction maps). In form A, I found one polymorphic restriction site in the rDNA arrays (Fig. 2.2, Type 1). In contrast, each form B individual showed multiple restriction site patterns represented by five different restriction site maps (Fig. 2.2). Three of the form B rDNA array types are similar to the form A pattern in length and restriction sites (Fig. 2.2, Type 1), but the remainder of form B restriction map sites are restricted to form B individuals (Fig. 2.2, Type 2).

Hybridization of ribosomal markers to DNA in interphase cells revealed a modal number (in at least 80% of observed cells) of three nucleolar organizing regions (NORs) per cell in form A individuals, but seven NORs per cell in form B individuals (Fig. 2.3). Occasional counts were plus or minus one NOR, possibly due to visual overlap of NORs in individual cells. The greater than two-fold increase of visible NORs in form B compared to form A is consistent across all cells.

Nuclear phylogenies of American samples

Sequences cloned from the same clam were not monophyletic in either the ITS-1 or 28S nuclear phylogenies (Fig. 2.4). Several ITS-1 sequences cloned from form B contain an insertion of 161 bp, which was expected based on the mapped

rDNA array variants (Fig. 2.4). Phylogenetic analysis of this locus (in which the insert was deleted from the analysis; see *Methods*) place the alleles with the insertion in a separate clade with high support (BPP = 1.0), regardless of whether the clam had the form A or form B mitochondrial COI haplotype (Fig. 2.4, Type 2). The remainder of form B alleles are found in clades with form A and form C (Fig. 2.4, Type 1). The 28S tree had a similar topology to the ITS-1 tree; although I cannot link any individual sequence unequivocally to my restriction-site map data, there is a strongly supported clade of form B clones similar to the ITS-1 Type 2 clade (BPP = 1.0).

Population-level mitochondrial analyses

In the American invasive *Corbicula*, a given cytochrome oxidase I (COI) mitochondrial haplotype is usually species-specific. However, in three of four river drainages sampled (7 of 9 sampling locations) where form A and form B are sympatric, some North American form B individuals showed the form A mitochondrial haplotype, and one form A individual showed the mitochondrial haplotype of form B (Table 2.2). Form A was fixed for the form A haplotype both in the allopatric population sampled (Spindle Top Branch; Table 2.1) and where it occurs in sympatry with form C (Table 2.3). Form C individuals were fixed for a third unique mitochondrial haplotype.

Androgenetic Corbicula are not monophyletic on mtDNA trees

Maximum likelihood and Bayesian phylogenetic analyses of mitochondrial DNA across the various species of *Corbicula* did not support a single clade of mitochondrial lineages from androgenetic species. On the mitochondrial tree,

androgenesis is polyphyletic with respect to diploid sexually reproducing species (Fig. 2.5). My analyses identified four androgenetic clades, and each of the three American mitochondrial lineages was nested within a separate clade (haplotypes H1: form A, H2: form B, H4: form C; Fig. 2.5). Analyses to test for long-branch attraction which removed outgroups did not result in different topologies. Hypothesis testing using mitochondrial data showed low support for a single androgenetic clade (Bayesian posterior probability, BPP = 0.034726) or for two androgenetic clades (BPP = 0.044208) (Table 2.4). Three androgenetic clades were found in nearly half of the sampled mitochondrial trees (BPP = 0.539508), primarily because H4 (form C) and H56 (*C. australis*) form a clade in about half the trees (BPP = 0.5109). Four separate clades were found in only about a third of the trees sampled (BPP = 0.381558). Overall, the hypotheses of three or four androgenetic clades received considerably higher support (53.9% and 38.1% of trees respectively) than the hypotheses of one or two clades (3.4% and 4.4% of trees respectively). Parametric bootstrapping also indicated that there was a significant difference in likelihood score between the MLE and the best tree constrained to have androgenetic taxa monophyletic ($P < 0.001$), and a significant difference in likelihood score between the MLE and the best tree constrained to have two separate clades of androgenetic taxa ($P < 0.001$).

DISCUSSION

I used a variety of molecular techniques to examine possible genetic interactions between sympatric species of androgenetic lineages in the clam genus

Corbicula. I analyzed genetic data from two species that have been introduced to North America to assess past or present interspecific nuclear gene exchange, and to test for egg-stealing with mitochondrial genome capture between species. These data provide insights into the evolutionary spread and maintenance of androgenesis.

Historic nuclear exchange between Corbicula

On the basis of restriction-site maps of nuclear rDNA arrays (Fig. 2.2) and sequence-based phylogenies (Fig. 2.4), I propose that form B originated from nuclear genome capture of a second species of *Corbicula* by a form A-like androgenetic ancestor. This genome capture event created a new androgenetic species that incorporated both the form A-like genome as well as part or all of the genome of the second species. The nuclear rDNA arrays of form A show the usual pattern of homogenization (Hillis and Dixon 1991), with a uniform repeat length and a single polymorphic site in the intergenic spacer (Figs. 2.1 and 2.2). However, there are five distinct rDNA arrays in all individuals of form B; these differ in the lengths of the intergenic and internal transcribed spacers, as well as in the number and type of restriction sites (which will correspond to base pair differences between array types). Although three of these patterns are quite similar to the rDNA repeats found in form A individuals (Fig. 2.2, Type 1), two patterns (Fig. 2.2, Type 2) are highly divergent from both form A and the other form B rDNA repeats. The presence of two distinct patterns within each individual clam suggests that the nuclear content of form B individuals may have origins in two separate evolutionary lineages.

Phylogenetic analyses of two sequenced markers within the rDNA repeats (Fig. 2.4), the first internal transcribed spacer (ITS-1) and a portion of the large ribosomal subunit (28S), also demonstrate nuclear diversity within form B. Previous sequence analysis of this 28S locus showed no diversity within form B clams (Lee et al. 2005). However, Lee et al. (2005) directly sequenced PCR products without the additional step of separating individual alleles prior to sequencing. If certain ribosomal alleles are preferentially amplified due to PCR reaction conditions (e.g. Buckler et al. 1997, Keller et al. 2006) only one sequence could be detected in the organism when more than one allele is actually present. In contrast, since I cloned individual sequence fragments, I was able to capture nuclear diversity within North American *Corbicula*. In particular, both ITS-1 and 28S phylogenies show at least one divergent, well-supported (BPP = 1.0) form B clade (Fig. 2.4). Based on the presence of a 161-bp insert in the ITS-1 sequence, this form B clade (Fig. 2.4) corresponds to the Type 2 ribosomal restriction patterns found only within form B (Fig. 2.2). The presence of multiple, divergent alleles in individuals is further evidence that form B clams contain nuclear DNA which originated from two separate nuclear lineages. The remainder of form B nuclear sequences group with form A sequences in the phylogenies. Although the Type I rDNA arrays are similar between forms A and B and suggest a recent common ancestor for this portion of their genomes, they can be distinguished in the restriction site analyses, and I see no evidence of any ongoing nuclear recombination between the two species in the rDNA restriction-site data. The lack of observed heterozygotes at diagnostic allozyme loci at the sympatric localities

sampled by Hillis and Patton (1982) and McLeod (1986) is also consistent with the absence or rarity of regular nuclear exchange between forms A and B.

The intragenomic sequence diversity detected in North American *Corbicula* compared to the lack of mitochondrial diversity is not unexpected. PCR-mediated error in replication of sequences (Tindall and Kunkel 1988, Bradley and Hillis 1997, Kobayashi et al. 1999) is likely in my data set, and will account for some of the variation around individual nodes in the nuclear phylogenies (Fig. 2.4). I cannot distinguish this *in vitro* error from natural variation that can be observed between the hundreds of copies of the rDNA genes, particularly in asexuals (e.g. Gandolfi et al. 2001, Feliner et al. 2004, Keller et al. 2006). However, this minor variation does not detract from my argument that major differentiated rDNA clades exist within form B, particularly as these are consistent with the RFLP analysis. Highly divergent rDNA genes can indicate two divergent ancestral species (as in Hugall et al. 1999, Lim et al. 2000, Muir et al. 2001), and the reduction of concerted evolution and gene conversion (as in Gandolfi et al. 2001, Mes and Cornelissen 2004, Keller et al. 2006). These multiple ribosomal haplotypes can be maintained in a genome over periods spanning millions of years (e.g. Muir et al. 2001, Keller et al. 2006).

The nucleolar organizer regions (NORs) are the chromosomal locations of the rDNA tandem repeats. Concerted evolution of the tandem repeats occurs through a combination of gene conversion and unequal crossing over during recombination between homologous chromosomes (Hillis and Dixon 1991). Form A is triploid (Lee et al. 2005), and *in-situ* hybridization of interphase cells with an rDNA probe

revealed three NORs, consistent with one NOR per haploid chromosome set (Fig. 2.3A). Chromosome counts of form B ($n = 54$; R. Baker and S. Hedtke, unpub. data) suggest form B is also triploid since it has the same number of chromosomes as form A (Lee et al. 2005) and as triploid *C. leana* (Okamoto and Arimoto 1986). However, *in-situ* hybridization of form B cells shows seven visible NORs in each cell rather than only three (Fig. 2.3B). Therefore, form B likely has multiple NORs per chromosome set. This apparent discrepancy between ploidy and the number of NORs could be resolved if the homologous chromosomes of two ancestral genomes have recombined in form B, resulting in chromosomes that have duplications of the NORs with rDNA arrays present from both ancestral genomes. These multiple chromosomal locations of NORs per haploid chromosome set in form B could explain why homogenization between these sets of rDNA arrays (especially via unequal crossing over) is limited (Hillis and Dixon 1991, Copenhaver and Pikaard 1996, Parkin and Butlin 2004), and why polymorphisms in the ribosomal sequence are observed within all form B individuals.

The greater diversity of rDNA arrays, the presence of multiple clades of rDNA sequences, and the incongruence between ploidy and NOR number in form B clams compared to form A clams could all be the consequence of hybrid origins for form B prior to its introduction to the U.S., which caused greater genetic and chromosomal diversity. The clonal nature of androgenesis appears to have resulted in fixation of this diversity across individuals of form B.

Nuclear recombination between androgenetic Corbicula is rare

Restriction site maps of nuclear ribosomal RNA genes and their associated spacer regions (rDNA) are uniform within each morphotype among all localities, but consistently distinct between forms A and B at sympatric as well as allopatric localities (Fig. 2.2). The distinct rDNA arrays of the two morphotypes at all sympatric localities means they are acting like distinct species, with no regular, ongoing nuclear recombination evident. The uniformity of the diagnostic nuclear rDNA arrays across the introduced range of the two forms, together with the diagnostic allozymic and morphological characteristics reported by Hillis and Patton (1982) and McLeod (1986), confirms that two distinct species of androgenetic *Corbicula* have been introduced to North America. However, the detection of a few polymorphic allozyme loci in populations of form B where it is sympatric with form A (McLeod 1986) suggest that, if these data are accurate, there is a possibility for rare incorporation of genes from one species to the other. Nonetheless, given that other allozyme loci in the same sympatric population examined by McLeod (1986) are fixed for different alleles in the two forms, the observed polymorphism cannot be the result of ongoing hybridization.

Mitochondrial-morphotype mismatch common in North America

In North American invasive *Corbicula*, most individuals of the same morphotype share a mitochondrial haplotype (Lee et al. 2005; this study). However, I detected mitochondrial lineages discordant with morphology in three of four sampled river drainages with sympatric populations of forms A and B (Table 2.3). Since little or no recent nuclear genetic exchange seems to have occurred between morphotypes,

this mitochondrial mismatch has three possible explanations: (1) heteroplasmic mitochondrial DNA; (2) population polymorphism in the ancestor of both species; (3) egg-stealing between species resulting in mitochondrial capture. Mitochondrial capture would occur after a sperm from one species stole an egg of the other species. The egg's nuclear DNA would be ejected, and offspring would inherit only the sperm's nuclear DNA. Offspring would inherit maternal mitochondria, creating a mismatch between the nuclear genome from the paternal species and the mitochondrial genome from the maternal species.

I do not believe that my results can be explained by the presence of heteroplasmic mtDNA. There is no evidence in animals for solely paternal inheritance of mitochondria, although paternal leakage can occur rarely (e.g. humans: Bromham et al. 2003; fruit flies: Satta et al. 1988, Kondo et al. 1990; mice: Gyllensten et al. 1991). However, double uniparental inheritance (DUI) has been detected in two bivalve families: Unionidae (Liu et al. 1996) and Mytilidae (Zouros et al. 1992). In these groups, the male gametic tissue retains mitochondria from both sperm and egg, while male somatic tissue and females retain mitochondria only from the egg (Fisher and Skibinski 1990). Male and female mitochondrial genomes can become quite divergent (e.g., nucleotide sequences have diverged by about 20% between the male and female mitochondrial genomes of *Mytilus galloprovincialis*; Mizi et al. 2005). Both DUI and paternal leakage is typically detected by PCR amplification of more than one divergent sequence within an individual (Fisher and Skibinski 1990, Zouros et al. 1992). I ran multiple PCR amplifications of the gonadal tissue of a form B clam

with form A mitochondrial sequence, and found that this discordant sequence was the only allele amplified (similar results in Stepien et al. 1999). Thus, DUI or paternal leakage leading to heteroplasmic mtDNA is unlikely to be the source of nuclear and mitochondrial discordance in North American *Corbicula*.

Retention of mitochondrial alleles from a common polymorphic ancestral population seems unlikely given the mitochondrial phylogeny (Fig. 2.5). The two mitochondrial lineages found in form A (haplotype H1) and form B (haplotype H2) are distinct lineages, separated by unique mitochondrial sequences found in sexual species and other androgenetic taxa (Fig. 2.5). In addition, any ancestral polymorphism would have to be retained through many bottleneck events, often likely involving single individuals, as these introduced species invaded drainages across North America. This makes retained polymorphism an extremely unlikely explanation.

Ongoing egg-stealing (the genetic capture of eggs through androgenesis) between sympatric North American *Corbicula* species could explain the observed mitochondrial discordance (Lee et al. 2005, Table 2.3). My results suggest that egg-stealing can occur spontaneously between species in *Corbicula*. This ability to steal the eggs of another species may result in more than just the capture of mitochondrial genomes. Within a population of conspecifics, egg stealing can cause rare partial nuclear genome capture: incomplete extrusion of the maternal genome after penetration of unreduced, androgenetic sperm has been observed in laboratory populations of *C. fluminea*, causing a rise in ploidy level (Komaru et al. 2001, 2006).

If this were to happen between an androgenetic clam and one of its close sexual or androgenetic relatives, chromosomes from both would contribute to offspring, which would in turn carry alleles for androgenesis and potentially could reproduce clonally. This type of nuclear genome capture between species explains the observed data in form B clams. An androgenetic ancestor of form A could have combined genomes through egg-stealing with another androgenetic or a sexual species, such that the resulting form B contained nuclear chromosomes from multiple species, but the mitochondrial DNA of the second ancestor. Given that forms A and B occur in both Asia as well as in introduced populations in North America, the origin of these species must predate their introduction to the New World.

Table 2.1. Sampling locations of *Corbicula* species, and number of clams from each sampling location used in a particular laboratory procedure. COI = mitochondrial COI sequenced; ITS-1 = ITS-1 sequenced, number of individuals (number of cloned sequences); 28S = 28S sequenced, number of individuals (number of cloned sequences); Map = restriction digest of rDNA; *In situ* = *in situ* hybridization of NOR.

Population location	Number of clams per procedure				
	COI	ITS-1	28S	Map	<i>In situ</i>
Argentina: Río de la Plata					
Ensenada					
Form A	7			10	
Form C	10	1 (7)			
Atalaya					
Form A				10	
Korea: Fish Market					
<i>C. japonica</i>	4				
Mexico: Río San Juan					
Castillos					
Form A				10	
Netherlands: River Lek					
Form A	2			10	
Netherlands: River Waal					
Form C	2				
USA: Arizona: Drainage canal					
Phoenix					
Form A	10			10	
Form B	10			10	
USA: Georgia: Savannah River					
1.6 km upstream of Georgia					
Hwy 119					
Form A				7	
USA: Illinois: Lake Michigan					
Chicago					
Form A				10	
USA: Texas: Blanco River					
Near mouth at San Marcos					
River					
Form A				10	
USA: Texas: Colorado River					
Webberville					
Form A	25			10	
Form B	25	1 (7)	1 (8)	10	
Hornsby					
Form A	10				
Form B	10				
Longhorn Dam					
Form A	10			10	
Form B	10			10	

Table 2.1 continues on next page.

Table 2.1, continued.

Population location	COI	ITS-1	28S	Map	<i>In situ</i>
USA: Texas: Little Brazos River, (Brazos River drainage) Crossing of Texas Hwy. 21					
Form A	9			10	
Form B	10			10	
USA: Texas: Llano River (Colorado River drainage) Roosevelt (N. Llano River)					
Form A				10	
Headsprings (S. Llano River)					
Form A				10	
USA: Texas: Pinto Creek (Rio Grande drainage) Crossing of US Hwy 90					
Form A	9			10	
Form B	9			10	
Crossing of RR 1008					
Form A				10	
Form B				10	
USA: Texas: Pecos River (Rio Grande drainage) Pandale					
Form A	10	1 (7)	1 (8)		
Form B	7	1 (6)	1 (6)		
USA: Texas: San Gabriel River (Brazos River drainage) Georgetown					
Form A	20	1 (8)	1 (8)		3
Form B	20				3
Crossing of Texas Hwy 29					
Form A	11			10	
Form B	11			10	
USA: San Saba River (Colorado River drainage) Crossing at Hwy 864					
Form A				8	
USA: Texas: Spindletop Branch Drainage ditch near Winnie					
Form A	10				
Total	261	5	4	235	6

Table 2.2. GenBank numbers and localities for each haplotype designation. Species designation indicated when known; *Corbicula* outside of its native range have not yet been conclusively identified. Haplotypes are based on 564 bp of the mitochondrial COI gene. Some sequences were trimmed to fit this length. Sperm morphology is indicated when known for at least one species within the haplotype group. Biflagellate sperm are considered a marker for androgenesis, whereas monoflagellate sperm indicates sexual reproduction (Glaubrecht et al. 2003).

Haplotype	Country	GenBank Accession No.	Sperm morphology
H1	China, France, Germany Japan (<i>C. leana</i>), Korea, Netherlands (this study), Thailand (<i>C. fluminea</i>), United States (form A; this study)	AF519495-507, AF196268, AF196280-81, AF269090, AF269092-3, AY097263- 75, AY943243, DQ285577	biflagellate ^{1,2}
H2	China, France, Korea, Japan, United States (form B; this study)	AF120666, AF196278-9, AF196269 AF519509-11, AY097300, AY097308-11	biflagellate ²
H3	Germany	AY097276	
H4	Argentina (Form C; this study), France, Germany, Netherlands (this study)	AF269095, AF519508, AY097277-81	biflagellate ²
H5	China, France, Indonesia (<i>C. javanica</i> , <i>C. subplanata</i> , <i>C. linduensis</i>), Netherlands	AF269096-8, AY275668, DQ285600-3, DQ285579	
H6	Germany	AY097283	
H7	Germany	AY097284	
H8	Germany	AY097285	
H9	Germany	AY097286	
H10	Germany	AY097287	
H11	Germany	AY097288	
H12	Germany	AY097289	
H13	Germany	AY097290	
H14	Germany	AY097291	
H15	China	AY097292	
H16	China	AY097293	
H17	China	AY097294	
H18	Israel	AY097295-8	
H19	Israel	AY097299	
H20	Taiwan	AF457991	
H21	China	AF457990	
H22	China	AF457989	
H23	Korea	AF457992	
H24	Germany	AY097301	
H25	France	AY097302	
H26	France	AY097303	
H27	France	AY097304	
H28	France	AY097305	
H29	France	AY097306	
H30	France	AY097307	
H31	Indonesia	AF457993	
H32	Japan	AY097312	
H33	Japan	AY097313	

Table 2.2 continues on the next page.

Table 2.2, continued.

Haplotype	Country	GenBank Accession No.	Sperm morphology
H34	Japan	AY097314	
H35	Japan	AY097315	
H36	Japan (<i>C. japonica</i>)	AF196271	monoflagellate ³
H37	Germany	AY097262	
H38	Germany	AY097282	
H39	Argentina	AF519512	
H40	Indonesia (<i>C. loehensis</i>)	AY275666, DQ285580	monoflagellate ⁴
H41	Indonesia (<i>C. loehensis</i>)	AY275667, DQ285581	monoflagellate ⁴
H42	Indonesia (<i>C. matannensis</i>)	AY275663	monoflagellate ⁴
H43	Indonesia (<i>C. matannensis</i>)	AY275664	monoflagellate ⁴
H44	Indonesia (<i>C. matannensis</i>)	AY275665	monoflagellate ⁴
H46	Indonesia (<i>C. possoensis</i>)	AY275662	monoflagellate ⁴
H47	Indonesia (<i>C. moltkiana</i>)	AY275657	monoflagellate ⁴
H48	Indonesia (<i>C. moltkiana</i>)	AY275658	monoflagellate ⁴
H49	Indonesia (<i>C. moltkiana</i>)	AY275659	monoflagellate ⁴
H50	Indonesia (<i>C. moltkiana</i>)	AY275660	monoflagellate ⁴
H51	Japan (<i>C. japonica</i>)	AF367440	monoflagellate ³
H52	Japan (<i>C. japonica</i>)	AF367441	monoflagellate ³
H53	Madagascar (<i>C. madagascariensis</i>)	AF196275	
H54	Netherlands	AF269091	
H55	France	AF269094	
H56	Australia (<i>C. australis</i>)	AF196274	biflagellate ⁵
H57	Japan (<i>C. sandai</i>)	AF196273	monoflagellate ⁶
H58	Japan (<i>C. sandai</i>)	AF196272	monoflagellate ⁶
H59	Thailand (<i>C. fluminea</i>)	AF196270	
H60	United States	U47647	biflagellate ²
H61	Vietnam	AF468018	
H62	Vietnam	AF468017	
H63	China	AF457999	
H64	China (<i>C. fluminalis/C. cf japonica</i> ⁷)	AF457998	
H65	China (<i>C. fluminalis/C. cf japonica</i> ⁷)	AF457997	
H66	China (<i>C. fluminalis/C. cf japonica</i> ⁷)	AF457996	
H67	China (<i>C. fluminalis/C. cf japonica</i> ⁷)	AF457995	
H68	China	AF457994	
H69	Korea (fishmarket; this study)	EU090397	
H70	Korea (fishmarket; this study)	EU090396-7, EU090399	
H71	Indonesia (<i>C. anomioides</i>)	DQ285604	
H72	Indonesia (<i>C. anomioides</i>)	DQ285605	
H73	Indonesia (<i>C. possoensis</i>)	DQ285596	monoflagellate ⁴
H74	Indonesia (<i>C. possoensis</i>)	DQ285597	monoflagellate ⁴
H75	Indonesia (<i>C. possoensis</i>)	DQ285598	monoflagellate ⁴
H76	Indonesia (<i>C. possoensis</i>)	DQ285599	monoflagellate ⁴
H77	Indonesia (<i>C. matannensis</i>)	DQ285591	monoflagellate ⁴
H78	Indonesia (<i>C. matannensis</i>)	DQ285592	monoflagellate ⁴
H79	Indonesia (<i>C. matannensis</i>)	DQ285593	monoflagellate ⁴
H80	Indonesia (<i>C. matannensis</i>)	DQ285594	monoflagellate ⁴
H81	Indonesia (<i>C. matannensis</i>)	DQ285595	monoflagellate ⁴
H82	Indonesia (<i>C. matannensis</i>)	DQ295587, DQ285590	monoflagellate ⁴
H83	Indonesia (<i>C. matannensis</i>)	DQ285586	monoflagellate ⁴

Table 2.2 continues on the next page.

Table 2.2, continued.

Haplotype	Country	GenBank Accession No.	Sperm morphology
H85	Indonesia (<i>C. matannensis</i>)	DQ285589	monoflagellate ⁴
H86	Indonesia (<i>C. matannensis</i>)	DQ285583, DQ285585	monoflagellate ⁴
H87	Indonesia (<i>C. matannensis</i>)	DQ285582	monoflagellate ⁴
H88	Indonesia (<i>C. matannensis</i>)	DQ285584	monoflagellate ⁴
H89	Thailand (<i>C. lamarckiana</i>)	DQ285578	
H90	Unknown (“ <i>C. fluminea</i> ”)	DQ264393	
H91	Unknown (“ <i>C. fluminea</i> ”)	AY874525	
Outgroups:			
<i>Neocorbicula limosa</i>	Argentina	AF196277	monoflagellate [?]
<i>Polymesoda caroliniana</i>	United States	AF196276	monoflagellate [?]

¹ Konishi et al. 2001; ² Lee et al. 2005; ³ Komaru et al. 1997; ⁴ Glaubrecht et al. 2003; ⁵ Byrne et al. 2001; ⁶ Hachiri and Higashi, 1970 (as cited in Konishi et al. 2001); ⁷ Korniushev (2004) finds that specimens labeled *C. fluminalis* from China are significantly different from those from the *C. fluminalis* type locality, and suggests they might instead group with *C. japonica*.

Table 2.3. Data on mismatches between mitochondrial haplotype and species identification for North and South American *Corbicula*. Number of individuals of each species with the mitochondrial marker (mtDNA) of the other species compared to the total of each species collected.

River Drainage	Form B with form A/total collected	Form A with form B/total collected	Form C with form A/total collected	Form A with form C/total collected
Río de la Plata, Argentina (1 location)			0/10	0/7
Phoenix, Arizona, USA (1 location)	0/10	0/10		
Brazos River drainage, Texas, USA (3 locations)	11/44	0/42		
Río Grande drainage, Texas, USA (2 locations)	1/16	1/19		
Colorado River drainage, Texas, USA (3 locations)	38/45	0/45		
Total	50/115	1/116	0/10	0/7

Table 2.4. Bayesian posterior probabilities of alternative tree topology hypotheses, given a post-burn-in sample of 181,912 trees. Haplotypes for androgenetic *Corbicula* are H1 (form A), H2 (form B), H4 (form C), and H56 (*C. australis*) (see Table 2.2). Haplotypes for sexual *Corbicula* and the outgroup taxa are not specified in this table for simplicity, but can be found in Table 2.2.

Hypothesis	BPP
One androgenetic clade	
((H1,H2,H4,H56), sexual))	0.034726
Two androgenetic clades	
((H1,H2,H4),H56,sexual))	0.000225
((H1,H2,H56),H4,sexual))	0.001946
((H1,H4,H56),H2,sexual))	0.039459
((H2,H4,H56),H1,sexual))	0.002067
((H1,H2),(H4,H56),sexual))	0.000005
((H1,H4),(H2,H56),sexual))	0.000066
((H1,H56),(H2,H4),sexual))	0.000044
Total	0.044208
Three androgenetic clades	
((H1,H2),H4,H56,sexual))	0.000632
((H1,H4),H2,H56,sexual))	0.020318
((H1,H56),H2,H4,sexual))	0.049612
((H2,H4),H1,H56,sexual))	0.000698
((H2,H56),H1,H4,sexual))	0.000885
((H4,H56),H1,H2,sexual))	0.467363
Total	0.539508

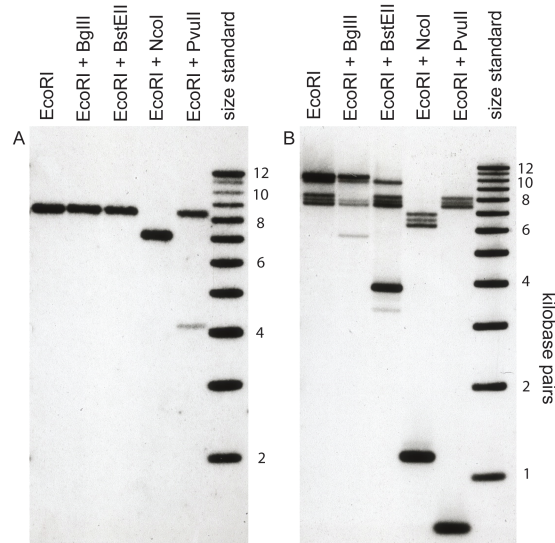

Figure 2.1. Example autoradiograms of Southern blots from restriction digests of (A) form A and (B) form B *Corbicula* genomic DNA, hybridized to radioactively-labeled 28aa primer. In (A), the 8.3 kb fragment seen in lanes A1, A2, A3, and A5 corresponds to the fragment bounded by the conserved Eco RI site near the end of the 28S gene, through the intergenic spacer, to the conserved Eco RI site near the end of the 18S gene in the adjacent repeat (see Fig. 2.2). The 4.2 kb low-copy-number fragment seen in lane A5 is the result of the polymorphic Pvu II site seen in some copies of the IGS of form A *Corbicula*. The 7.1 kb fragment in lane A4 corresponds to the Eco RI to Nco I fragment from the 28S gene into the IGS of form A. In contrast to the uniformity of the rDNA array length seen in form A, individuals of form B *Corbicula* (seen in autoradiograph B) show five distinct array lengths (the Eco RI to Eco RI fragments of the five arrays are 7.4, 7.6, 8.1, 9.9, and 10.1 kb in length). In comparing lanes B1 and B2, note that the Bgl II site in the IGS is confined to just one of the five rDNA arrays (the 8.1 kb fragment is the only one cut). Similarly, Bst EII sites are only present in the IGS of the 10.1 fragment (see lane B3, and note the low-frequency polymorphism present in this array). The two Type 2 arrays share an Nco I site in the IGS (lane B4: note the high-frequency 1.2 kb fragment), and all the arrays have a conserved Nco I site in the 18S gene (which produces fragments of 6.2, 6.4, and 6.9 kb in the three Type I arrays). Finally, the two Type 2 arrays in form B share a Pvu II site in the 28S gene, which produces the ~0.8 kb fragment in lane B5).

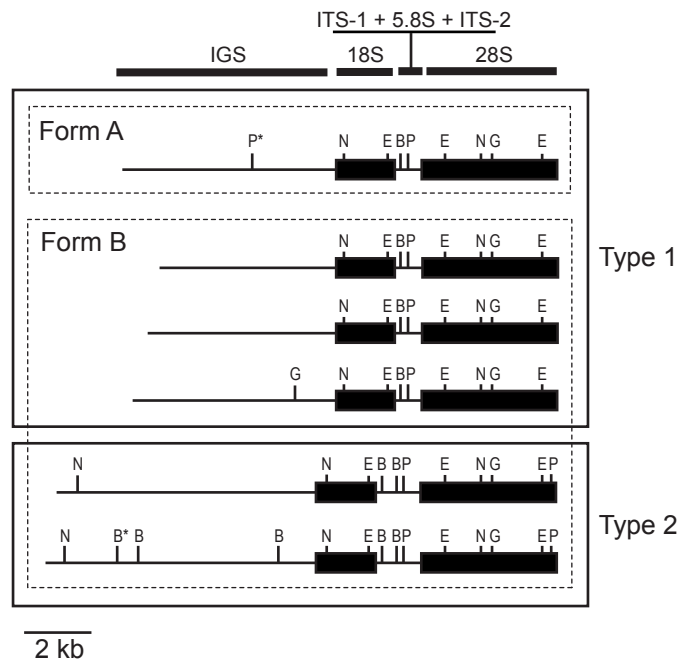

Figure 2.2. Restriction-site maps of ribosomal DNA repeat regions in North American *Corbicula* form A and form B. Restriction sites for a given enzyme are noted (P: Pvu II, N: Nco I, E: Eco RI, B: Bst EII, G: Bgl II). The diversity of array types in form B clams represents diversity within individual clams. IGS = intergenic spacer; ITS-1 = internal transcribed spacer 1; ITS-2 = internal transcribed spacer 2. The asterisk indicates a polymorphic restriction site (present in some copies of the array but not in others). These arrays are repeated in tandem in the genome, so hundreds of copies of each array are present in a given individual. Type 1 share restriction site patterns across 18S, ITS-1, 5.8S, ITS-2, and 28S, but differ in length and restriction pattern of IGS. Type 2 differs from Type 1 in the restriction pattern for 28S, the pattern and length of ITS-1 + 5.8S + ITS-2, and the pattern and length of the IGS.

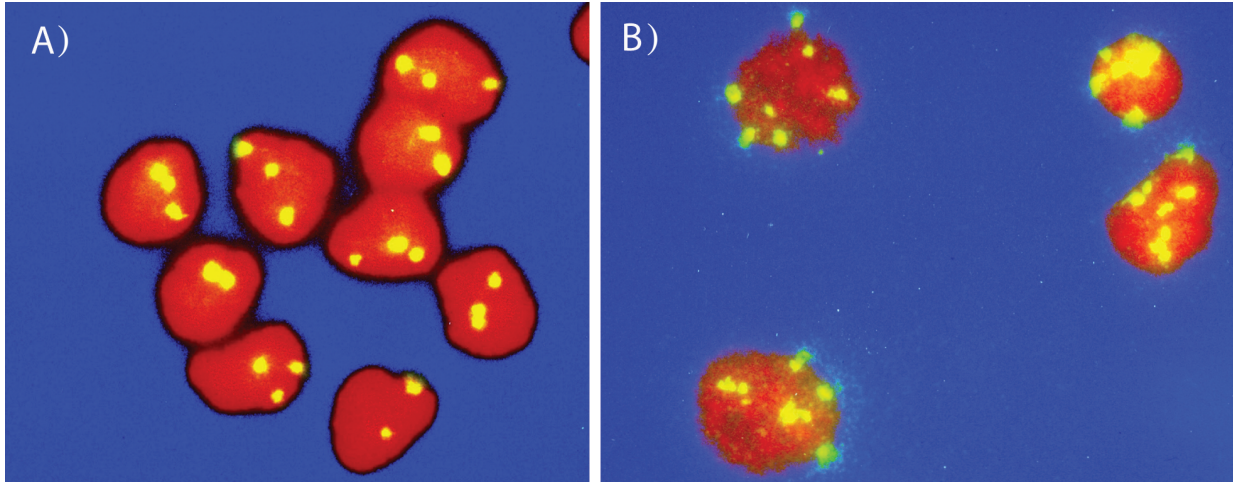

Figure 2.3. *In-situ* hybridization of ribosomal RNA repeats in invasive form A and form B collected from San Gabriel River, Texas, USA. Cells fluoresce red; light areas indicate where RNA probes have attached to chromosomes at the nucleolar organizing regions (NORs). Representative cells from each form are shown. (A) Form A *Corbicula* show three distinct NORs per cell. (B) Form B *Corbicula* show 7 to 9 distinct NORs per cell.

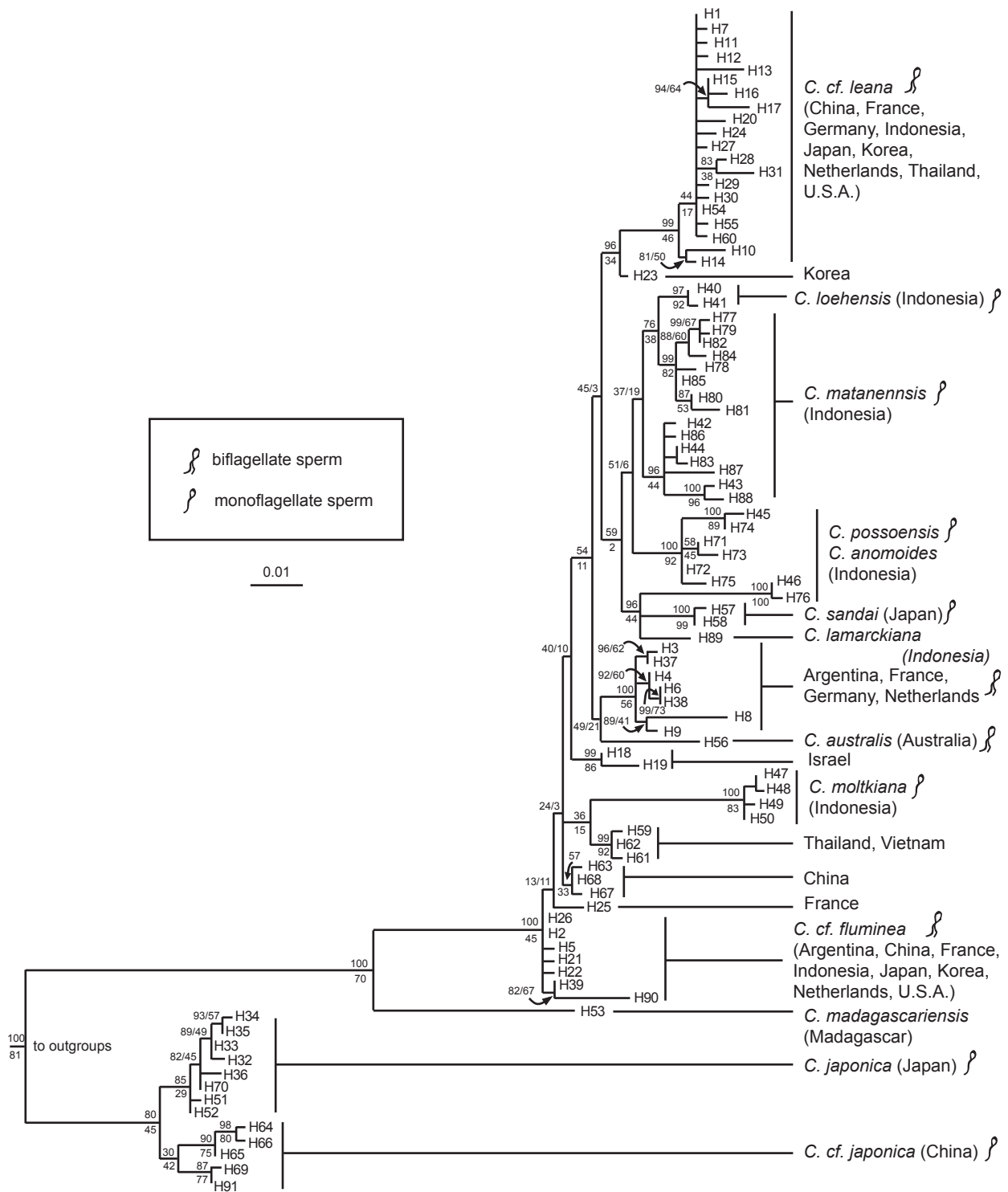

Figure 2.5. Bayesian consensus tree of the mitochondrial COI locus across haplotypes of *Corbicula* (see Table 2.2), with branch lengths optimized under maximum likelihood. Bayesian posterior probabilities (in percentages) are labeled above the branch; maximum likelihood bootstrap percentages are below. Biflagellate sperm is diagnostic of androgenetic reproduction; *Corbicula* with monoflagellate sperm are dioecious and reproduce sexually (see Table 2.2 for details).

Chapter 3: The Origin and Maintenance of Androgenesis in

Corbicula

I have found evidence that androgenetic species of *Corbicula* can capture the eggs of another species to produce paternal clones (Chapter 2). If this is the case, my mitochondrial phylogeny across species (Fig. 2.5) may not be an accurate reflection of organism history. This phylogeny shows the four species of androgenetic *Corbicula* as polyphyletic with respect to sexually reproducing species (Fig. 2.5), with Bayesian posterior probabilities suggesting as many as three or four separate clades (Table 2.4). However, since the mitochondrial phylogeny tracks the maternal lineage alone, what appears to be multiple origins of androgenesis may be a consequence of using mitochondrial data to create the phylogeny. There may have been only one, relatively recent origin of androgenesis, followed by egg-stealing and capture of the mitochondrial genome of related sexual species. In this case, the mitochondrial phylogeny would represent the original species phylogeny, and not reflect egg-stealing events.

To distinguish between potential explanations for multiple androgenetic lineages of *Corbicula*, I analyzed nuclear data from multiple genes across the global distribution of *Corbicula*. If androgenesis had a single origin, followed by egg parasitism, all androgenetic clams should share one common set of nuclear chromosomes (Figure 1.1A). Phylogenetic analysis of nuclear sequence data should therefore show one clade of closely related alleles found in all androgenetic clams. If

rare nuclear genome capture between species occurs (as I have suggested for form B *Corbicula*) there may be additional distinct nuclear alleles found in different androgenetic species (Figure 1.1C). If androgenesis has multiple, independent origins (Fig. 1.1B), I expect alleles from androgenetic individuals to be polyphyletic or nested within the sexual lineages of their origin. A hybrid origin of androgenesis would result in two separate clades of alleles shared between androgenetic taxa, assuming that alleles are retained over time (Birky 1996) and that sexual descendants of both parental species are sampled (Fig. 1.1A,B).

The origins of androgenesis and subsequent genetic interactions between lineages affect expectations for the genetic consequences of male asexual reproduction in *Corbicula*. In particular, in the absence of genetic exchange, androgenetic clams would be driven to extinction due to lack of genetic variability and accumulation of harmful mutations (Chapter 1). However, if asexual clams are able to capture nuclear genes from other species during egg-stealing, extinction of the species may be delayed because of increased adaptive variation and partial masking of harmful mutations.

METHODS

Species sampled

In addition to those tissue samples collected in Chapter 2 (see Table 2.1), I received ethanol-preserved tissue samples of *C. australis*, *C. cf. elongata*, *C. fluminea*, *C. fluminalis*, *C. loehensis*, *C. matannensis*, *C. moltkiana*, and *C. tobiae* from Dr. Matthias Glaubrecht, and *C. fluminea*, *C. leana*, and *C. madagascariensis*

from Dr. Diarmaid Ó Foighil (Table 3.1). This represents a reasonable sampling of *Corbicula* throughout its native range.

Although I extracted DNA successfully from Korean ethanol-preserved tissues using Viogene DNA Blood and Tissue Genomic extraction kits (Viogene Biotek Corp.), I extracted a larger quantity using a standard phenol-chloroform protocol modified by suggestions in Watt and Watt (1992) as quantified by a spectrophotometer (data not shown). Therefore, I extracted these tissue samples using the modified phenol-chloroform protocol.

Primer development

To identify nuclear markers appropriate for phylogenetic analysis, I tested a candidate set of "universal" primers (primers developed from sequenced genes shared between multiple divergent eukaryotic taxa) and primers I developed using an α -amylase gene sequence from *Corbicula* (GenBank accession AF468016; Table 3.2). Primer pairs were tested on DNA from North America and Korea using PCR annealing temperatures ranging from 44-56°C, and run on an ethidium-bromide stained gel. Those pairs with bands were optimized by varying temperature and concentrations of magnesium chloride or BSA. I cleaned successful amplifications using a Viogene Gel-M Gel extraction kit (Viogene Biotek Corp.), sequenced, and ran on an Applied Biosystems 3100 automated sequencer. I designed several additional primer pairs using some of these initial sequences to attempt to increase sequence quality. If sequences from North American *Corbicula* indicated that the

marker might be variable enough for phylogenetic analysis, I increased taxon sampling and cloned and sequenced PCR products as described in Chapter 2 Methods. Table 3.1 lists the number of clones sequenced per individual per locus for those markers that were potentially informative (28S, ITS-1, INT, TUB, α -amylase and ATPS- α), and how many of these sequences were different from each other within a given individual. Although the INT, TUB, and ATPS α primers were universal primers designed to amplify specific introns, I could not confirm the identity of my sequences amplified by these primers, because there are no existing sequences for these introns on GenBank for any *Corbicula* or their close relatives. Sequenced introns for these genes are therefore putative ("put").

Binning of alleles

Cloning and sequencing introduce noise into a data set, since *Taq* polymerase makes some errors in replication (Tindall and Kunkel 1988, Bradley and Hillis 1997, Kobayashi et al. 1999), and these errors can be sampled by cloning. Thus, multiple sequences from one individual may not represent genetic alleles, but rather PCR error. The number of unique sequences sampled per individual (Table 3.1) suggests this may be a problem for my data. To reduce noise due to PCR error, I binned clones such that a separate "allele" was called if there were more than three base pair differences between that sequence and another group of sequences. The consensus sequence for each bin was the most common base pair sampled across sequences in the bin, or coded using IUPAC ambiguity rules if two base pairs were equally

represented between sequences at a given site. Although somewhat arbitrary, this binning procedure was primarily intended to reduce difficulty in tree visualization, and I used both un-binned and binned sequences in phylogenetic analyses to ensure that binning did not significantly alter the results.

Alignments

Alignments of sequence data were performed manually using MacClade (Maddison and Maddison 2000). I trimmed the ends of each alignment to exclude regions of missing data. Regions of uncertainty did exist in my alignments. For each aligned data set, I ran analyses in which I included all ambiguous regions (sites which contained indels) and analyses in which ambiguous regions were excluded (number of base pairs per alignment: 28S: 414 bp with ambiguous regions included, 359 bp with ambiguous regions excluded; ITS-1: 539 bp; put-TUB: 186 bp; put-INT: 298 bp; AMY: 560 bp with ambiguous regions included, 379 bp with ambiguous regions excluded; put-ATPS: 347 bp with ambiguous regions included, 263 bp with ambiguous regions excluded). This allowed me to infer whether the inclusion or exclusion of data affected phylogenetic results. I combined sequences identical in the included regions to form a single haplotype.

To build a species tree, I concatenated nuclear and mitochondrial allele sequences sampled across different single-copy genes (560 bp from AMY, 347 bp from put-ATPS, and 584 bp from COI). A complication is that separate alleles found within a species cannot be individually identified as homologous between species, so a concatenated alignment must use only one allele per species. For sexual species, I

selected one nuclear allele per individual by coin flip. For androgenetic species, I used the most commonly shared nuclear allele, and performed separate analyses using mitochondrial haplotypes H1 (shared by *C. leana*, Form A, and some Asian *Corbicula*; Tables 2.2, 3.1), H2 (shared by Form B and various Asian *Corbicula*; Tables 2.2, 3.1), and H62 (shared by *C. fluminea* from Thailand and various Asian *Corbicula*; Tables 2.2, 3.1). I generated an additional phylogeny with Form C nuclear and mitochondrial sequences (haplotype H4 from Table 2.2, 3.1). I analyzed alignments with and without androgenetic taxa to examine their effect on the relationships between sexual taxa.

Testing for recombinant sequences

During PCR, recombination can occur between alleles of an individual and confound phylogenetic analysis (Bradley and Hillis 1997). I used the program RDPv3.26 (Martin et al. 2005b) to test all sequences for possible PCR-mediated recombination within individual PCR products using the following implemented methods: RDP (Martin and Rybicki 2000), GENECONV (Padidam et al. 1999), Bootscan/Recscan (Martin et al. 2005a), MaxChi (Maynard Smith 1992), Chimaera (Posada and Crandall 2001), SiScan (Gibbs et al. 2000), and 3seq (Boni et al. 2007). In no case was recombination inferred between sequences found in an individual, suggesting PCR-mediated recombination was not a problem for my datasets.

Phylogenetic analyses

I performed phylogenetic analyses on both the un-binned, aligned sequence data and on putative allelic sequence data. I determined the model of evolution for all

alignments under the Akaike Information Criterion using ModelTest v3.7 (Posada and Crandall 1998) for maximum likelihood analyses, and MrModelTest v2.3 (Nylander 2004) for Bayesian analyses, employing the correction for sample size (i.e., the AICc). I used the number of bases in the alignment as the sample size. I estimated the maximum likelihood estimate (MLE) for all trees using GARLI v0.96 (Zwickl 2006), performing twenty search reps for each alignment. I ran either one hundred (ITS-1, put-TUB, AMY) or one thousand (28S, put-INT, put-ATPS) nonparametric bootstrap replicates using GARLI under the same search settings as those used to determine the MLE. For Bayesian phylogenetic analysis, I performed four replicate runs with four chains each using MrBayes v.3.1.2 (Ronquist and Huelsenbeck 2003). I set the exponential rate parameter for the distribution of the prior probability on branch length to 0.01 rather than the default of 0.1, as analyses performed by myself and others indicate that the default branch length prior in MrBayes can lead to branch lengths ten to over a hundred times larger than the MLE estimate if distances between sequences are suspected to be small (Brown et al., unpublished). My prior expectation was that branch lengths would be much shorter than 0.1. I allowed each run to continue for 5,000,000 generations and sampled every 1,000 trees and parameters. For concatenated alignments, I ran both unpartitioned and partitioned analyses. I assessed convergence using MrConverge (as described in Brown and Lemmon 2007).

I used FigTree v1.1 (Rambaut 2006) to visualize trees and create initial graphics files. For most markers (with the exception of 28S and put-TUB), the

outgroup taxon *C. cf. japonica* either did not amplify or sequences were too divergent from the freshwater ingroup to successfully align. Topologies are therefore unrooted for these markers (although midpoint rooting is used for convenience of visualization).

Hypothesis Testing

The posterior probability of alternative hypotheses was determined by filtering the post-convergence Bayesian posterior sample using backbone constraints in PAUP* v.4b (Swofford 2002). Since topologies are sampled in proportion to their posterior probability once stationarity has been reached, the proportion of trees within the post burn-in sample which matches a given constraint tree represents the probability of that topology. For each of the three putatively single-copy genes (COI, AMY, and put-ATPS), I tested the monophyly of alleles within each androgenetic individual, the monophyly of all alleles from all androgenetic taxa, support for the CONCAT topology, and pairwise relationships between sexual taxa.

RESULTS

Primers useful for phylogenetic analysis

Most universal primers did not amplify a region of DNA sufficiently variable for phylogenetic analysis (Table 3.2). Two primer pairs (Tub 3 and 4, INT A and INT B) amplified regions which, after phylogenetic analysis, appeared to be part of a gene duplication (discussed below). I did not perform hypothesis testing on these or ribosomal (28S and ITS-1) trees since all orthologs were not likely to have been sampled. Two primer pairs amplified regions of DNA which were variable and did

not appear to have been duplicated (AMYe3c and AMYe4a, ATPSash1 and ATPSash4; Table 3.2). These sequences were used in hypothesis testing and are discussed below.

Phylogenetic trees

Phylogenies were created for five nuclear markers: 28S (Fig. 3.1), ITS-1 (Fig. 3.2), putative Tub intron (put-TUB; Fig. 3.3), putative INT intron (put-INT; Fig. 3.4), α -amylase intron 3 (AMY; Figs. 3.5, 3.6), and putative ATPS- α intron (put-ATPS; Fig. 3.7). The amount of sequence data trimmed from the analysis did not make a difference in topological support, and caused only minor differences in branch lengths. I present results for alignments which excluded all indels and uncertainty. Phylogenetic analysis of put-TUB (Fig. 3.3) and put-INT (Fig. 3.4) revealed more than two clades with alleles from single sexual individuals. Since sexual species are presumably diploid (*C. sandai* is known to be diploid; Okamoto and Arimoto 1986), the presence of more than two alleles suggests gene duplication. 28S (Fig. 3.1) and ITS-1 (Fig. 3.2) are part of the nucleolar organizing region, which contains up to hundreds of copies of the ribosomal genes. Alleles found within individuals are not monophyletic on these ribosomal trees.

In the two remaining phylogenies, AMY (Figs. 3.5, 3.6) and put-ATPS (Fig. 3.7), when sexual individuals have more than one sequence, those sequences are closely related to each other, as expected. Some asexual individuals, however, contain very divergent sequences. Hypothesis testing indicates that sequences of a single

androgenetic individual are not always their closest relatives, even though other androgenetic alleles are permitted to be nested within that single individual's group. Neither are asexual lineages as a whole monophyletic (Table 3.3).

Although individual species have divergent alleles, androgenetic species share identical or similar alleles not shared by sexual species. In both the AMY and put-ATPS tree, there is a single sequence shared across multiple androgenetic taxa. This similarity suggests recent shared history among androgenetic species.

The topologies resulting from analyses of the concatenated data set (CONCAT) did not differ whether the most permissive or most exclusive alignment was used or whether partitioned or unpartitioned analyses were run. The subtraction of taxa with missing data (i.e., taxa for which all markers were not sequenced) or the removal of androgenetic sequence data also made no difference in results. When sequences from either form A, form B/*C. fluminea* Korea, or *C. fluminea* Thailand were used to represent androgenetic *Corbicula* in the mitochondrial partition (COI), the support for all bipartitions was the same. I present the results for the alignment which included taxa with missing sequence but excluded indels (Fig. 3.8).

Gene trees have conflicting topologies

Three phylogenies, AMY, put-ATPS, and COI, were tested to see whether observed differences in topology were due to lack of resolution between trees or represented well-supported alternate trees (Table 3.3). The posterior probability of the major bipartition found in CONCAT (androgenetic lineage+*C. moltkiana*+*C. sandai* separated from *C. loehensis*+*C. matannensis*+*C. madagascariensis*; Fig. 3.8) was

0.0003 for COI and 0.0 for put-ATPS. The AMY topology, however, had a posterior probability of 0.9996 for the CONCAT bipartition. To test whether there was a single taxon responsible for gene tree incongruence with the concatenated topology, I removed each taxon from the backbone constraint and determined posterior probabilities of each of the new reduced topologies. None of the six taxa (sexual or asexual) caused all gene trees to be consistent with CONCAT when removed from consideration. To identify which bipartitions may cause differences between gene tree topologies, I found the posterior probability of each pair of sexual species being sister taxa. To test whether well-supported topological differences between sexual taxa were being driven by their relationships to androgenetic taxa, I also found the posterior probability of pairs of sexual taxa allowing androgenetic alleles to be nested within the pair. Those clades with posterior probabilities greater than 0.5 in any dataset are reported in Table 3.3. My results indicate that there is well-supported incongruence in the relationships of sexual taxa between gene trees. Because androgenetic individuals are themselves non-monophyletic, I did not test relationships between androgenetic taxa, although the lack of individual monophyly in itself means that both AMY and put-ATPS are incongruent with the mitochondrial COI tree.

DISCUSSION

I evaluate several hypotheses which could explain androgenetic species diversity in *Corbicula*, given their lack of monophyly on a mitochondrial gene tree (Fig. 2.5). (1) Androgenesis may have multiple origins, due to either repeated loss-of-function mutations (Fig. 3.9A) or due to hybridization events between sexual species.

(2) Androgenesis may have a single origin, with capture of divergent mitochondrial genomes after egg-stealing by androgenetic sperm (Fig. 3.8B). (3) Androgenesis may have a single origin, with egg-stealing by androgenetic species rarely accompanied not only by capture of mitochondria, but also of maternal nuclear DNA (Fig. 3.9D). (4) Combinations of these processes may have acted in this system to form morphologically and genetically distinct androgenetic species. I propose that egg-stealing by androgenetic species, with capture of maternal mitochondrial and nuclear DNA, has played an important role in shaping the evolutionary history of *Corbicula*.

Gene tree incongruence and the Corbicula species tree

Several different approaches use multiple genetic markers to estimate a species tree (the phylogeny which represents the history between species rather than between alleles). The first is to concatenate the available data into a single alignment, which can be analyzed under either one model of evolution or using models which partition the dataset by marker or by other characteristics (e.g., coding vs. non-coding regions of a gene). Under this approach, individual gene tree incongruence is presumed to be swamped out by true phylogenetic signal across markers, and the resulting tree is assumed to represent species relationships (e.g., Rokas et al. 2003). The second set of approaches considers individual gene histories separately, and infers the species tree based on those gene trees. The simplest of these methods is building a consensus topology of individual gene trees, assuming that histories found commonly in the gene trees represent species relationships. Another method, reconciliation, assigns costs to processes which might cause incongruence, and finds

the species tree which minimizes those costs required to reconcile gene trees with a particular species tree (e.g., deep coalescences or gene duplications and losses; Maddison 1997, Page and Charleston 1998). A growing number of approaches explicitly consider population processes such as incomplete lineage sorting or hybridization and have built coalescent models into species tree inference (e.g. Buckley et al. 2006, Carstens and Knowles 2007, Liu and Pearl 2007). Unfortunately, these implementations require assumptions of effective population size, which in *Corbicula* is complicated by the presence of sexual, asexual, and polyploid species.

I have used the concatenation approach to generate a potential species tree (Fig. 3.8). However, this may not be a good estimate of species relationships. Each of the three individual gene trees (mitochondrial cytochrome oxidase I: COI, Fig 2.5; nuclear α -amylase 3rd intron: AMY, Figs. 3.5, 3.6; nuclear putative ATPS- α intron: put-ATPS, Fig 3.7) has statistically supported, incongruent relationships between species (Table 3.3). Gene tree incongruence can have underlying biological causes or may be due to systematic error in the analysis. For example, one gene may be prone to long-branch attraction while another is not because of differences in the rate of evolution (Hedtke et al. 2006). Of the three gene trees considered, the only obvious topology for which long-branch attraction might have been a problem was COI (Fig. 2.5). When the outgroups to *Corbicula* (*Neocorbicula* and *Polymesoda*) and the outgroups to the freshwater *Corbicula* (*C. cf. japonica*) were removed from analysis, I did not find that relationships within freshwater *Corbicula* changed significantly.

This suggests that incongruence between mitochondrial and nuclear gene trees was not likely a result of problems associated with long-branch attraction.

Certain biological processes lead to topological incongruence between gene trees. Given the short branch lengths inferred between taxa, freshwater *Corbicula* seem to have recently radiated, with rapid morphological evolution (Glaubrecht et al. 2003), making incomplete lineage sorting between sexual taxa a plausible source of incongruence. Gene duplication and loss of nuclear genes also cannot be rejected as a possible process which could confuse topological inference, although to explain the observed topologies, duplication would have occurred early in the history of the genus, and different copies independently lost in almost all species.

A final biological process which could cause topological incongruence between gene trees is hybridization and capture of mitochondria. Given what we know about the mechanisms of androgenesis in *Corbicula* (Komaru et al. 1998, Ishibashi et al. 2003), these processes are highly likely to have caused discordance between mitochondrial and nuclear gene trees. These gene tree incongruences, rather than obscuring origins of androgenetic species diversity, can instead reveal processes important to *Corbicula's* history.

Origin of androgenesis in Corbicula

Multiple, morphologically distinct species of *Corbicula* are identified as androgenetic through cytological examination of fertilization (Komaru et al. 1998, 2000, Ishibashi et al. 2003) or the presence of genetic invariance, polyploidy, and biflagellate sperm (Hillis and Patton 1982, McLeod 1986, Byrne et al. 2000,

Korniushin 2004, Lee et al. 2005). The phylogenetic trees do not support a simple scenario of a single origin and subsequent diversification (Fig. 3.9A), or of repeated, multiple origins (Fig. 3.9B). In both of those scenarios, mitochondrial and nuclear phylogenies are expected to be congruent.

Instead, the observed phylogenetic pattern is what I expect under a relatively recent origin of androgenesis, followed by post-origin hybridization as asexual taxa spread and came into contact with different sexual species (Fig. 3.9D-F). Most androgenetic individuals share a single allele (e.g., 'ABDE' in Fig. 3.9E), or are found in a clade of closely-related alleles (e.g., 'ADF' in Fig. 3.9F). This suggests that androgenesis has evolved relatively recently in the genus, possibly from a common ancestor shared with *C. sandai*, the sexual species found closely related to androgenetic taxa across phylogenies.

Some individual asexuals contain a highly divergent nuclear allele in addition to the shared sequence (e.g., 'D' in Fig. 3.9E, or 'E' in Fig. 3.9F). The 'Meselson effect', when alleles within an asexual lineage diverge as they are retained and accumulate mutations over time (Birky 1996, Judson and Normark 1996), is not a convincing explanation for the within-individual diversity observed in *Corbicula*. In such a scenario, all alleles of a particular gene would be expected to accumulate differences. In other words, alleles within each species would be the same distance from their common ancestor. In *Corbicula*, both alleles are not equally divergent. Instead, one allele is very similar or identical across species, while the other allele is very divergent and not shared across androgenetic species. This suggests that the

divergent allele has not been generated by mutation over time, but is the result of nuclear genetic capture by an androgenetic lineage of DNA from another, more distantly related species. Since those androgenetic species which share an allele do not seem to share more than one allele in common, androgenesis appears to be mutational in origin rather than the result of a single hybridization event between sexual species.

Multiple hybrid origins could potentially explain the observed pattern, if a single sexual species hybridized with a number of divergent sexual species, and genetic interactions between incompatible genomes led to unreduced sperm and the breakdown of the signal pathway for meiosis in the egg. This single sexual species would have to have been widespread and have co-occurred with several other sexual species. Given that I have shown that androgenetic *Corbicula*, which have a widespread ecological distribution, appear able to steal eggs of other species, multiple hybrid events involving a hypothetical, formerly widespread but currently unsampled, sexual species seems less likely than nuclear capture by androgenetic clams.

My results suggest the possibility for a second, independent origin of androgenesis and subsequent mitochondrial capture (Fig 3.9C,E). I did not find the AMY allele commonly shared between androgenetic taxa ('ABDE' of Fig. 3.8E) in form C/Netherlands. This form C species groups with *C. moltkiana* across nuclear phylogenies, and could have had a separate mutational origin from a *C. moltkiana*-like ancestor. However, this conclusion is highly dependent on whether all alleles were successfully amplified and sequenced in this species. In the put-ATPS

phylogeny, an allele from form C is found in a common clade of androgenetic individuals (Fig. 3.9F). If the shared AMY allele was simply not sampled, then the divergent form C sequence found in that gene would be another instance of genetic capture, rather than evidence for a separate origin.

Mechanistically, genetic capture by androgenetic clams could have happened as a polyploidization event. Meiosis in the egg occurs after sperm fertilization in most animals. In androgenetic *Corbicula*, the meiotic spindle fibers do not orient perpendicular to the cell membrane, and so the entire maternal genome is extruded (Komaru et al. 1998, 2000, Ishibashi et al. 2003). However, within-species polyploidization has been observed in the lab, presumably because correct spindle fiber orientation allowed half of the maternal genome to be added to the unreduced paternal genome from the sperm rather than being eliminated (Komaru et al. 2006). *Corbicula* seems tolerant of polyploidy (androgenetic *Corbicula* can be diploid, triploid, and tetraploid; Okamoto and Arimoto 1986, Komaru et al. 1997, Komaru and Konishi 1999, Qiu et al. 2001). Alternatively, only a portion of the maternal genome might be retained through recombination between paternal and maternal chromosomes. The incorporation of maternal DNA from different species appears to be relatively rare, however, as androgenetic species in sympatry remain genetically distinct (see Chapter 2).

Species of Corbicula

Based on my phylogenetic analyses, several observations can be made about the species of *Corbicula* which have invaded Europe and America. First, one species

from the Netherlands shares both mitochondrial and nuclear sequences with form A from North and South America. The other species sampled from the Netherlands shares mitochondrial and nuclear sequence with form C from South America. These two species either originated from the same Asian source, or were transported to Europe from America. There may be a third European species which is not represented in our analyses (Renard et al. 2000). Unfortunately, none of the Asian species sampled here are the obvious source of the invasive taxa. Form B shares some genetic similarity to *C. fluminea* from Korea and Thailand and to *C. leana* from Japan. Form A (and the Netherlands species) share mitochondrial sequence with *C. leana* from Japan and is often associated with *C. fluminea* from Taiwan and the Philippines on nuclear trees.

Some individuals classified as *C. fluminea* may be more appropriately classified as distinct species. Historically, the species name *C. fluminea* has been applied to all freshwater *Corbicula* (Britton and Morton 1979), a practice incongruent with genetic and morphological distinctiveness (Hillis and Patton 1982, Glaubrecht et al. 2003, Korniusshin and Glaubrecht 2003). In nuclear phylogenetic trees, *C. fluminea* from Taiwan (species 'E' in Fig. 3.9E,F) is significantly different from *C. fluminea* from Korea and Thailand (species 'D' in Fig. 3.9E,F). Further systematic revision of *Corbicula* using morphological and genetic characters is clearly needed.

In the nuclear phylogenies, *C. sandai* is sister to or nested within androgenetic taxa (Figs. 3.1, 3.2, 3.5, 3.6, 3.7, 3.8). *Corbicula sandai* is an endemic sexual species found only in Lake Biwa, Japan, and is the only known freshwater *Corbicula* with

free-swimming larvae rather than internal incubation. Thus, its close relationship to internal brooding, hermaphrodite androgenetic species is surprising, particularly since it groups with other sexual taxa on the mitochondrial phylogeny. *Corbicula sandai* might have reverted to sexuality from an androgenetic ancestor. Reversion from androgenesis to sexuality may be difficult; in *C. fluminea*, even when maternal chromosomes are chemically prevented from leaving the egg, meiosis II cannot proceed (Ishibashi et al. 2006), while it does proceed in *C. leana* (Ishibashi et al. 2002). This suggests mutation accumulation in genes relating to sexual reproduction in *C. fluminea*, and that loss-of-function mutations in such genes may evolve relatively quickly.

Genetic consequences of androgenesis

Androgenetic individuals are expected to have a reproductive advantage over sexual members of the same population. Each androgenetic father passes on twice as many of his genes to his offspring than a sexual father does, and all of his offspring carry alleles for androgenesis (McKone and Halpern 2003). In hermaphrodite species, which have both male and female function, androgenetic hermaphrodites could pass on alleles for androgenesis through the maternal line as well, causing asexuality to spread further (McKone and Halpern 2003). I suggest androgenetic species may additionally benefit by being able to steal eggs from other, closely related species. Androgenetic alleles have been likened to selfish genetic elements such as sex chromosomes with meiotic drive and cytoplasmic male sterility (McKone and Halpern 2003), all of which can spread within a population at the expense of the

fitness of the species as a whole (McKone and Halpern 2003). However, I propose that androgenetic alleles in *Corbicula* cannot only be viewed as selfish genetic elements, but as elements that have potentially reduced the probability of extinction for these asexual lineages.

Androgenesis is expected to lead to selection for reduced female function in outcrossing hermaphrodites, since individuals that invest more energy in making sperm rather than eggs could produce more offspring at lower cost. This decreases overall population fitness and can lead to extinction (McKone and Halpern 2003). Androgenetic *Corbicula* have a high rate of selfing (Kraemer 1978), and frequent selfing can by itself lessen selection pressure for reduced female function (McKone and Halpern 2003). I propose an additional mechanism essential to the future maintenance of androgenesis within the genus *Corbicula*: the ability of androgenetic sperm to parasitize the oocytes of closely related species. In addition to the direct reproductive benefits of egg capture, androgenesis could benefit from infrequent chromosomal rescue. Harmful mutations could be masked by the addition of new genetic material from the maternal genome. This would allow usually clonal androgenetic species to slow the rate of deleterious mutation accumulation due to Muller's Ratchet (Muller 1964, Felsenstein 1974) and would introduce adaptive variation. As has been suggested for other asexual systems, such as parthenogenetic ostracods (Butlin et al. 1998), water fleas (Paland et al. 2005), and gynogenetic fish (Schartl et al. 1995a), androgenesis could continue to persist in *Corbicula* due to rare genetic exchange – rare sex. In the case of *Corbicula*, this would occur after stealing

the egg of another species, possibly accompanied by polyploidization due to incomplete extrusion of the maternal genome.

The impact of rare genetic exchange on the maintenance of asexual lineages depends on several important factors: the mechanism of spermatogenesis and the frequency of capture of genetic material. The mechanism of gametogenesis is often overlooked in studies which model relative fitness of asexuals and sexuals over time; the authors generally define asexuality as apomixis (clonal reproduction without recombination or segregation). However, a wide range of cytological mechanisms for gametogenesis are known in asexuals, and this affects the genetic consequences of asexual reproduction. Three known mechanisms for gametogenesis would permit triploidy and would therefore be applicable to androgenetic *Corbicula*. First, if sperm are generated through mitosis, then the advantages and disadvantages to asexual reproduction explored in most models would also define the relevant parameter space for the spread or maintenance of asexuality in *Corbicula*. The second mechanism, premeiotic doubling, duplicates the entire genome before meiosis. Pairing occurs between identical chromosomes, and recombination does not change the genotype between generations. The genetic expectations are therefore the same as for gametogenesis through mitosis (Maynard Smith 1989, Haccou and Schneider 2004). Finally, in central fusion, recombination does occur between homologous chromosomes, and central polar nuclei fuse before continuing on to produce unreduced gametes (Haccou and Schneider 2004). In this case, the fitness effects of deleterious mutation accumulation over time are not as severe as those expected

without meiosis, since recombination and segregation allow deleterious mutations to be purged from the population by selection (Haccou and Schneider 2004).

There is weak, indirect evidence that recombination may occur during spermatogenesis in *Corbicula*. McLeod (1986) observed extremely low average heterozygosity (frequency of 0.0025) in a population of form B that was sympatric with form A, despite a relatively high proportion of polymorphic loci in the population (0.227). At that time, self-fertilization was considered to be an explanation for the low levels of heterozygosity. Observed low heterozygosity can be an indication of high selfing rates in sexually reproducing taxa. In the case of androgenetic *Corbicula*, chromosomes from the sperm replace those of the egg, so selfing in the usual sense (sexual recombination of two genomes of the same individual) does not occur. However, this genetic pattern would also be observed if unreduced sperm were generated by central fusion. Gametes retain the same number of chromosomes as the somatic cell, but alleles have been shuffled due to recombination and segregation. Sperm production would decrease heterozygosity at individual loci: random assortment of alleles in a heterozygous father would produce both homozygous and heterozygous spermatozoa, but a homozygote father would only produce homozygotes. Over time, heterozygosity is lost, but the population may retain multiple alleles per locus until they are lost through drift or selection. If McLeod's (1986) data is not the result of lab-based error, the increased proportion of polymorphic loci in sympatry (but with very low levels of individual heterozygosity) would be a reflection of rare capture of portions of the maternal genome through

recombination of the two genomes before the maternal genome is extruded from the eggs, followed by segregation and recombination during spermatogenesis.

If central fusion occurs during spermatogenesis, homozygosity would increase over time at polymorphic loci. However, evidence suggests that heterozygosity is maintained over time, as would be expected if no recombination and segregation occurred (Birky 1996, Judson and Normark 1996). Multiple, distinct ribosomal arrays appear to be maintained in North American form B *Corbicula* (Fig. 2.2) and androgenetic *Corbicula* are heterozygous at the nuclear loci I sequenced. In addition, most loci are diagnostically distinct and invariable between the two North American invasive species (Smith et al. 1979, Hillis and Patton 1982, McLeod 1986, Lee et al. 2005, Chapter 2). This evidence does not support central fusion, and instead suggests mitotic or premeiotic doubling in spermatogenesis. Further cytological work on spermatogenesis in androgenetic *Corbicula* would be useful in determining whether recombination and segregation occurs in *Corbicula*. If it does, deleterious mutations could be purged from the population through selection (Kondrashov 1982, 1984, 1988, Haccou and Schneider 2004), further reducing *Corbicula*'s extinction probability.

Asexuals are expected to become extinct over evolutionary time, because they accumulate deleterious mutations more rapidly than sexuals, cannot free beneficial alleles from a poor genetic background, and must rely on mutation to combine new adaptations. The persistence of male asexuality, androgenesis, will depend in part on the process of spermatogenesis and on the frequency of rare genetic capture from

divergent lineages. Even a limited amount of outcrossing could reduce the effect of harmful mutations and increase beneficial adaptation (Pamilo et al. 1987). Thus, the mechanism which causes androgenetic reproduction in *Corbicula* could itself decrease the extinction risk of this peculiar form of asexuality.

Table 3.1. Species of *Corbicula* sequenced, and the number of sequences obtained through cloning, for multiple nuclear loci (see *Methods* for details). The mitochondrial haplotype (COI) is taken from Table 2.2. Since some sequences were identical, the number of sequences which differed per individual is indicated in parentheses.

Species of <i>Corbicula</i>	Country of origin	Collection number	COI	AMY	ATPS	28S	ITS	INT	Tub
<i>C. australis</i>	Australia	ZMB 106607	-	-	-	8(5)	-	-	1(1)
<i>C. cf. elongata</i>	Thailand	ZMB 200238	-	-	-	1(1)	-	-	-
<i>C. cf. japonica</i>	Korea	Kor 1	H70	-	-	8(3)	-	-	1(1)
<i>C. cf. japonica</i>	Korea	Kor 2	H70	-	-	-	-	-	2(2)
<i>C. cf. japonica</i>	Korea	Kor 3	H69	-	-	8(4)	-	-	1(1)
<i>C. cf. japonica</i>	Korea	Kor 4	H70	-	-	-	-	-	1(1)
<i>C. fluminalis</i>	Congo	ZMB 170399	-	-	-	7(5)	-	-	-
<i>C. fluminea</i>	Korea	UMMZ 266690	H62	7(6)	6(6)	7(3)	-	8(8)	3(3)
<i>C. fluminea</i>	Taiwan	ZMB 170096a	H20	8(2)	5(4)	8(4)	-	9(6)	4(4)
<i>C. fluminea</i>	Thailand	UMMZ 266691	H2	6(5)	7(6)	4(3)	-	7(7)	4(4)
<i>C. fluminea</i>	Philippines	ZMB 103026	-	-	8(3)	8(6)	-	-	1(1)
<i>C. fluminea</i>	Thailand	ZMB 200262	-	-	-	5(2)	-	-	-
<i>C. fluminea</i>	China	ZMB 103057	-	-	-	16(4)	-	-	-
<i>C. javanica</i>	Indonesia	ZMB 103054	-	-	-	6(6)	-	-	2(2)
<i>C. leana</i>	Japan	UMMZ 266687	H1	-	-	9(8)	-	-	-
<i>C. leana</i>	Japan	UMMZ 266688	-	-	-	6(4)	5(5)	-	-
<i>C. linduensis</i>	Indonesia	ZMB 103016	-	-	-	-	3(3)	-	-
<i>C. loehensis</i>	Indonesia	ZMB 190582 ZMB 190768	H41	6(4) 5(4)	5(2) 5(3)	7(3) 8(4)	-	4(4) 7(6)	4(4) 3(3)
<i>C. madagascariensis</i>	Madagascar	UMMZ 255293	H53	5(2)	-	8(3)	-	2(2)	2(2)
<i>C. matannensis</i>	Indonesia	ZMB 191042	H84	4(3)	4(4)	8(3)	-	6(3)	5(5)
<i>C. moltkiana</i>	Indonesia	ZMB 103024	H50	3(3)	3(3)	7(2)	-	5(5)	-
<i>C. moltkiana</i>	Indonesia	ZMB 103032	H48	-	-	8(6)	-	-	-
<i>C. possiensis</i>	Indonesia	ZMB 191043	-	-	-	6(4)	-	-	-
<i>C. sandai</i>	Japan	UMMZ 266689	H58	5(4)	6(2)	8(6)	14(8)	-	7(7)
<i>C. sp.</i>	Netherlands	fff2	H4	6(5)	7(2)	7(4)	5(5)	8(8)	6(6)
<i>C. sp.</i>	Netherlands	ggg1	H1	7(3)	8(4)	7(4)	8(6)	7(7)	5(5)
<i>C. sp. form A</i>	U.S.A.	xx1 xx7 xx10 xx11 ccc7 qq1	H1	- - - - - 8(3)	1(1) - 8(6) - - -	- - 8(5) 8(4) - -	- 8(8) - - 7(7) -	- - - 6(5) - -	- - 6(6) 3(3) - -

Table 3.1 continued on next page.

Table 3.1, continued.

Species of <i>Corbicula</i>	Country of origin	Collection number	COI	AMY	ATPS	28S	ITS	INT	Tub
C. sp. form B	U.S.A.	rr1	H2	3(2)	-	-	-	1	-
		rr3					6(6)	-	-
		rr6		-	-	-	-	3(2)	-
		tt6		-	-	-	-	4(4)	-
		yy12		7(5)	6(5)	7(5)	-	-	7(6)
		ddd4		-	-	7(3)	7(7)	-	-
C. sp. form C	Argentina	U1	H4	-	-	1	8(7)	-	4(4)
		U3		-	3(3)	-	-	4(3)	-
		U4		5(4)	-	-	-	-	-
C. tobiae	Indonesia	ZMB							
		103027	-	5(1)	6(2)	6(3)	-	5(3)	-
C. cf. japonica	Korea	Kor 2	H70	-	-	-	-	-	2(2)

Table 3.2. PCR amplification results from *Corbicula* genomic DNA for various primers for nuclear and mitochondrial genes.

Marker	Primer Pairs	Source	Generalized Result
12S	12sai/12smr 12sai/12sbi	Palumbi 1996	Low sequence variation between species
12S/16S	12said/16sbr	Palumbi 1996	Poor amplification; sequence did not align with 12S. Other 12S-16S primer combinations failed to amplify; 12S and 16S may not be contiguous in <i>Corbicula</i>
16S	16sar/16sd 16sar/16sbr	Palumbi 1996	Low sequence variation between species
28S	D23F/D4RB	Lee et al. 2005	Variable between species; multi-copy ribosomal gene
ACT	ACT I/ACT II	Palumbi 1996	Multiple bands; part of a small gene family
α-amylase	amye3c/amye4a amye4b/amye6c amye2e/amye3a	designed by SMH from GenBank accession no. AF468016	Variability between species Low sequence variation between species Low sequence variation between species
ANT	ANT-f1/ANT-r1	Jarman et al. 2002	Strong band, but unable to sequence
ATPS-α	ATPS α -SH1/ATPS α -SH4	Designed by SMH from sequence obtained using ATPS_ primers in Jarman et al. 2002	Variable between species
ATPS-β	ATPS β -f1/ATPS β -r1	Jarman et al. 2002	Strong band, but unable to sequence; cloning reactions unsuccessful
creatine kinase	CK6/CK7/ARK7	Palumbi 1996	Multiple bands; there appears to be multiple annealing spots within intron; no clean sequence obtained
cytochrome b	cytb397f/cytb811r UCYTB144f/ UCYTB272R/ UCYTB151F/ UCYTB270R	Dahlgren et al. 2000 Merritt et al. 1998	Low sequence variation between species
COI	HCO/LCO	Folmer et al. 1994	Variable between species

Table 3.2 continues on next page.

Table 3.2, continued

Marker	Primer Pairs	Source	Generalized Result
EF	EF0/EF1/EF2	Palumbi 1996	Low sequence variation between species
INT	INT A/INT B	Palumbi 1996	Variable between species, duplicate genes inferred
ITS-1	18dd/5.8ssh3	Hillis and Dixon 1991/ designed by SMH as described in Chapter 2	Variable between species, multi-copy ribosomal transcribed spacer
LTRS	LTRS-f1/LTRS-r1	Jarman et al. 2002	No consistent bands, poor quality sequence
SRP	SRP54-f1/SRP54-r1	Jarman et al. 2002	No bands
TBP	TBP-f1/TBP-r1	Jarman et al. 2002	No bands
Tub	Tub 3/Tub 4	Palumbi 1996	Low sequence variation between species, part of a gene family
ZMP	ZMP-f1/ZMP-r1	Jarman et al. 2002	No bands

Table 3.3. Posterior probabilities of monophyletic groups in three different gene trees of *Corbicula*. Androgenetic taxa were tested to determine the posterior probability that all sequences from one individual were found in a clade of only other androgenetic species; i.e., the posterior probability that no sequence from that individual was separated by sequence from any sexual species. The posterior probability of monophyly of all sequences from all androgenetic individuals, and of relationships between sexual taxa (with and without androgenetic sequences) was also determined.

Bipartition or clade tested	COI	AMY	ATPS
Monophyly of androgenetic individuals :			
Form A	n/a	0.14	0.53
Form B	n/a	0.01	0.20
Form C	n/a	0	0.0
<i>C. fluminea</i> Korea	n/a	0	0.14
<i>C. fluminea</i> Thailand	n/a	0	0.13
<i>C. fluminea</i> Taiwan	n/a	0.01	0.05
<i>C. fluminea</i> Philippines	n/a	n/a	0.53
Monophyly of all androgenetic individuals	0.03	0	0
Posterior probability of sexual taxa being sister:			
(<i>C. loehensis</i> , <i>C. matannensis</i>)	0.97	0.99	0
(<i>C. loehensis</i> , <i>C. moltkiana</i>)	0.02	0	0.33
(<i>C. madagascariensis</i> , <i>C. moltkiana</i>)	0.71	0	n/a
(<i>C. matannensis</i> , <i>C. sandai</i>)	0.01	0	0.99
(<i>C. moltkiana</i> , <i>C. sandai</i>)	0.21	0	0
Posterior probability of sexual taxa being closest sexual relatives, removing androgenetic taxa:			
(<i>C. loehensis</i> , <i>C. matannensis</i>)	0.97	0.99	0
(<i>C. loehensis</i> , <i>C. moltkiana</i>)	0.02	0	0.99
(<i>C. madagascariensis</i> , <i>C. moltkiana</i>)	0.76	0	n/a
(<i>C. matannensis</i> , <i>C. sandai</i>)	0.01	0	0.99
(<i>C. moltkiana</i> , <i>C. sandai</i>)	0.21	0.99	0

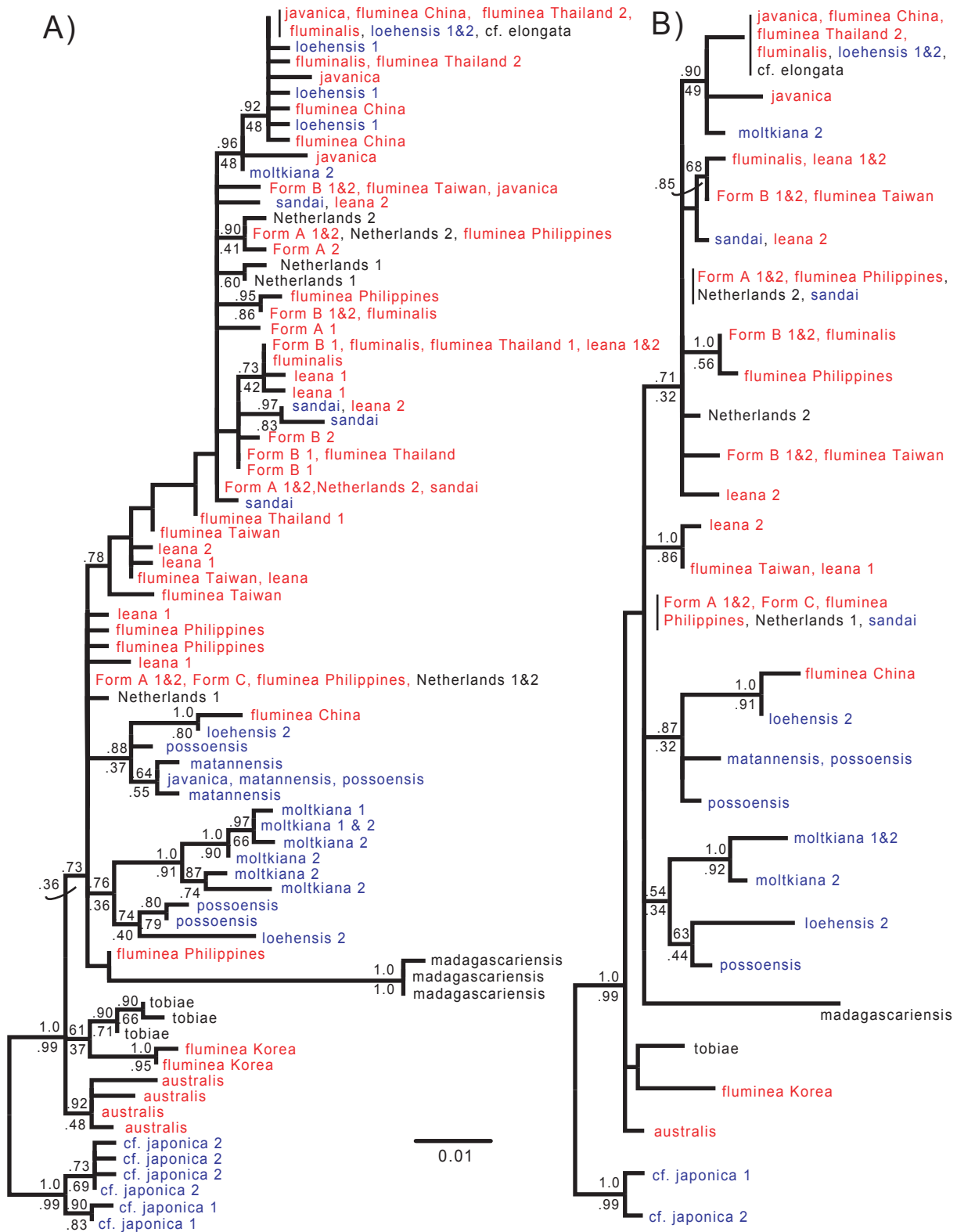

Figure 3.1. Maximum likelihood estimate of nuclear ribosomal marker 28S. Numbers above the branch indicate Bayesian posterior probabilities, numbers below are bootstrap proportions. *Corbicula cf. japonica* was used to root the tree. A) Phylogeny estimated using sequence data. B) Phylogeny estimated using sequences binned by similarity.

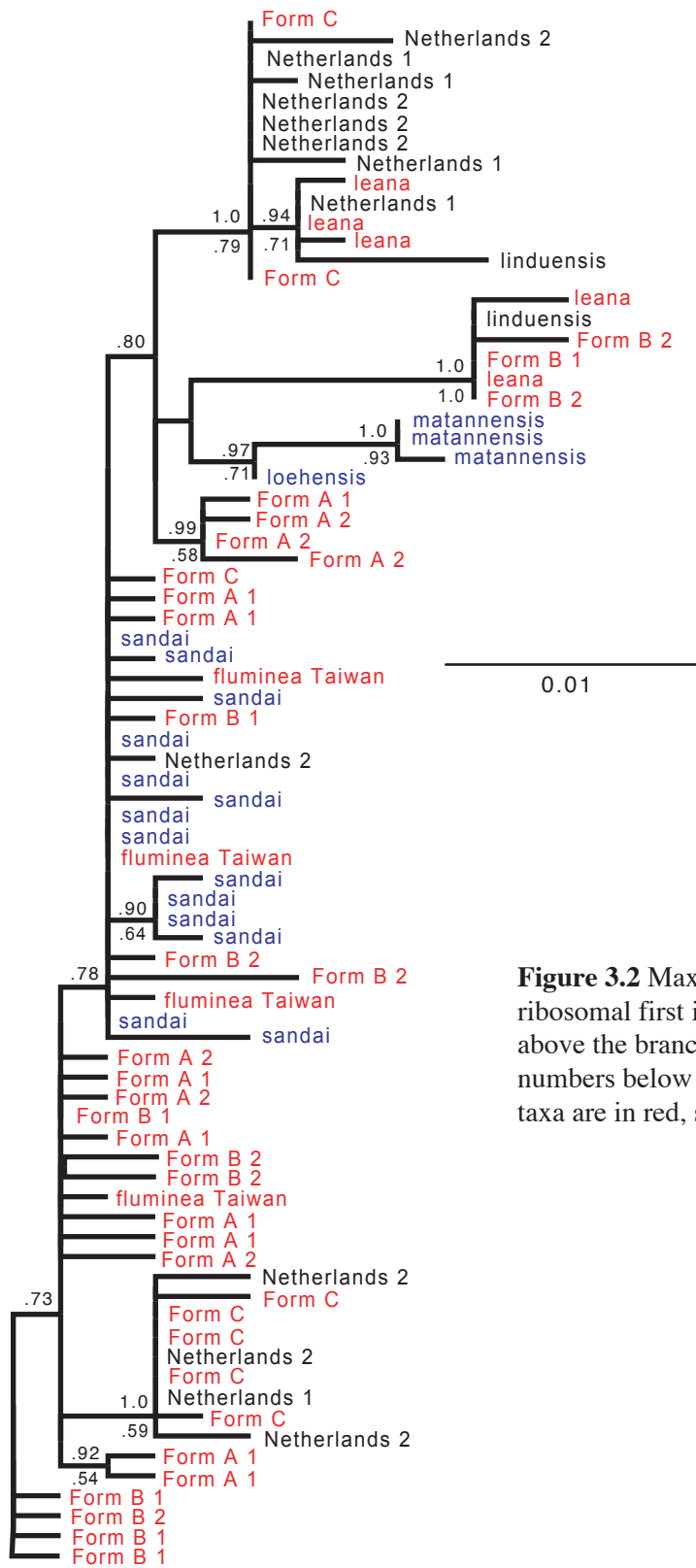

Figure 3.2 Maximum likelihood estimate of the nuclear ribosomal first internal transcribed spacer (ITS-1). Numbers above the branch indicate Bayesian posterior probabilities, numbers below are bootstrap proportions. Androgenetic taxa are in red, sexual taxa in blue. Tree is unrooted.

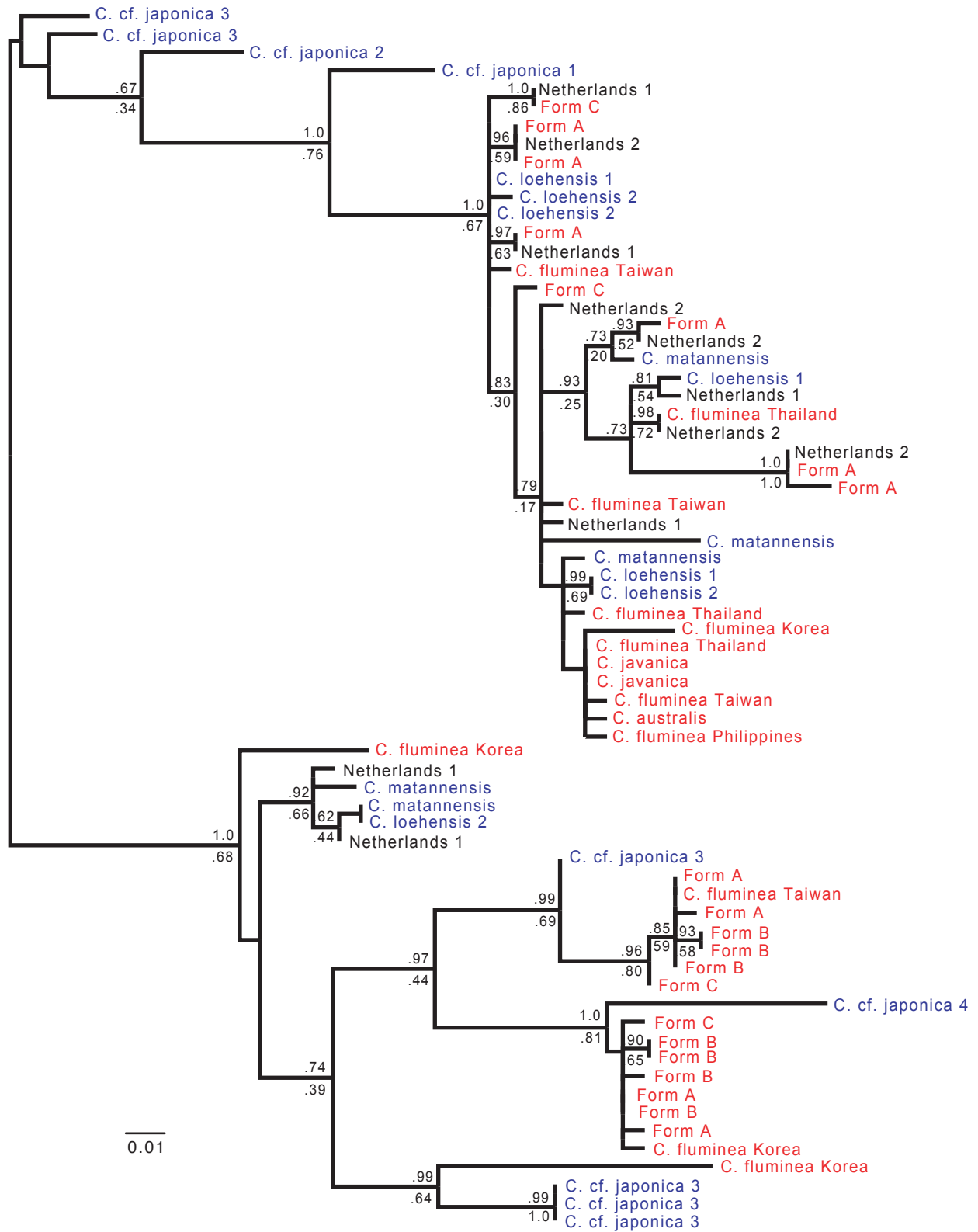

Figure 3.3 Maximum likelihood estimate of a putative nuclear tubulin intron (put- TUB). Numbers above the branch indicate Bayesian posterior probabilities, number below are bootstrap proportions. This marker is part of a small gene family. Tree has been rooted at the mid-point for visualization.

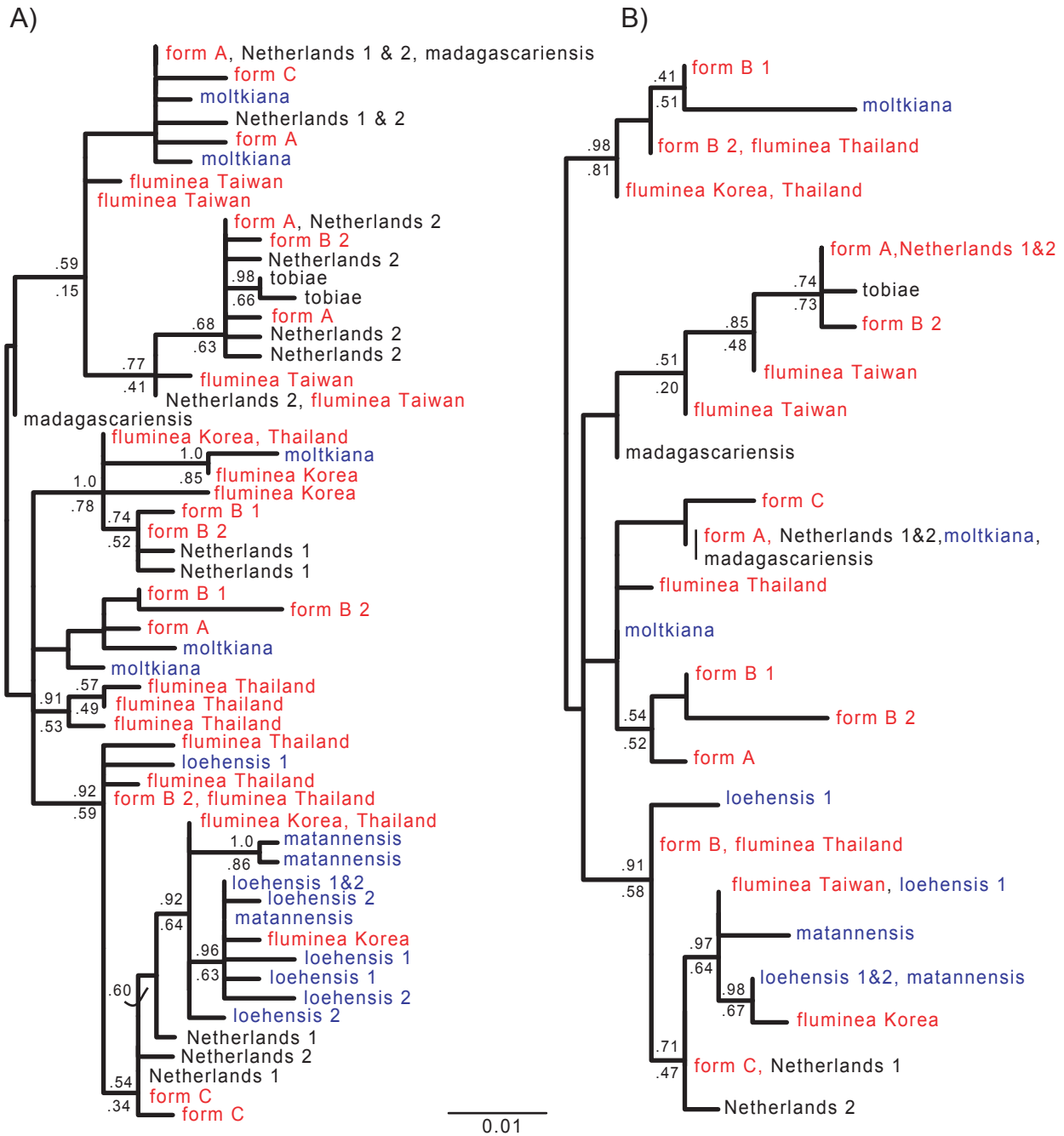

Figure 3.4 Maximum likelihood estimate of a putative nuclear INT intron. Androgenetic taxa are in red, sexual taxa are in blue. Numbers above the branch indicate Bayesian posterior probabilities, numbers below are bootstrap proportions. Trees have been mid-point rooted for visualization. Several diploid sexual species have more than two divergent alleles (*C. moltkiana*, *C. loehensis*), consistent with gene duplication. A) Phylogeny estimated using clone sequence data. B) Phylogeny estimated using sequences binned by similarity (see text for details).

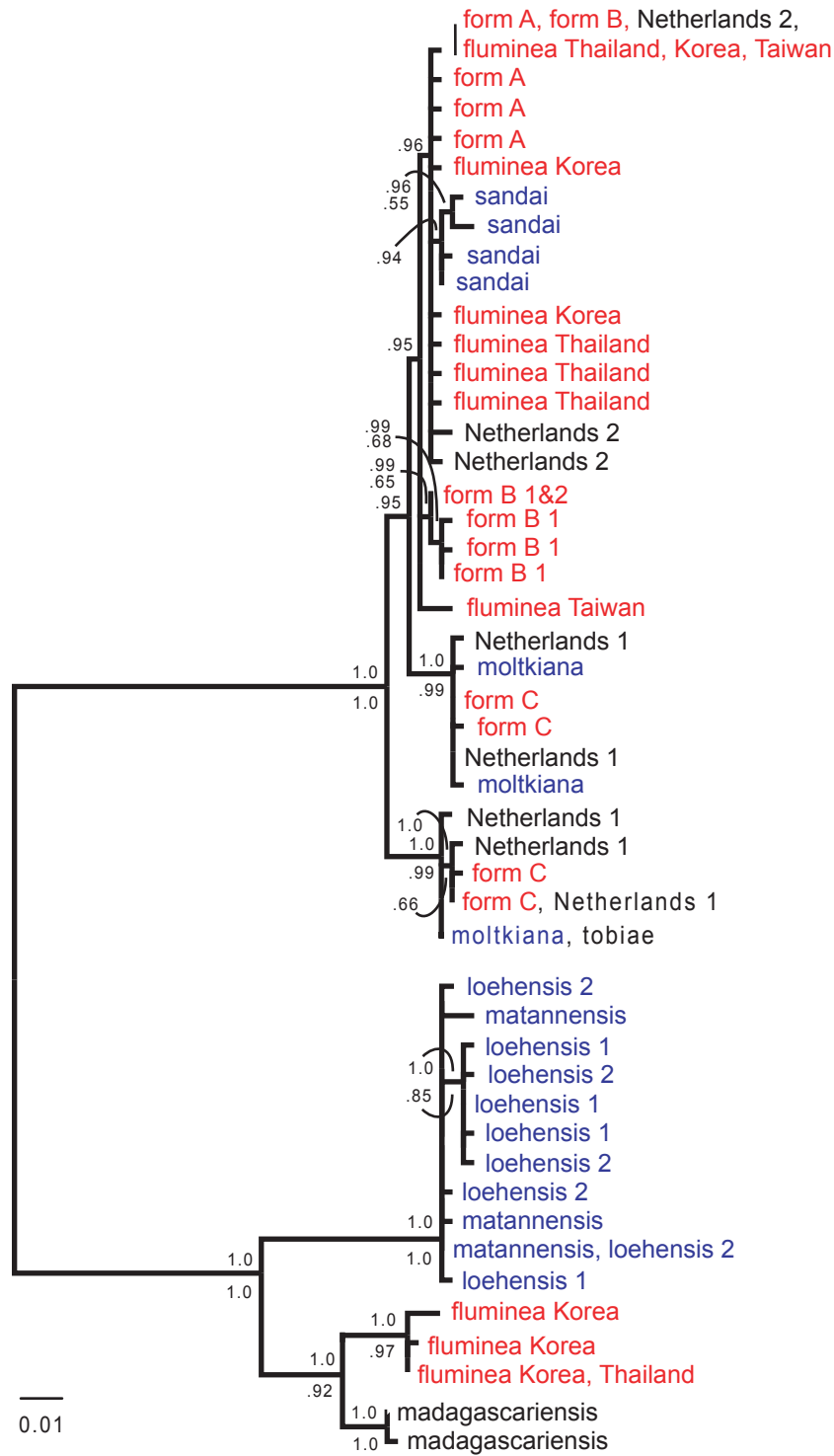

Figure 3.5 Maximum likelihood estimate of the third intron of the nuclear alpha-amylase gene (AMY) based on clone sequence data. Red indicates androgenetic species, blue sexual. Numbers above the branch indicate Bayesian posterior probabilities, number below are bootstrap proportions. Trees have been rooted with mid-point rooting for visualization.

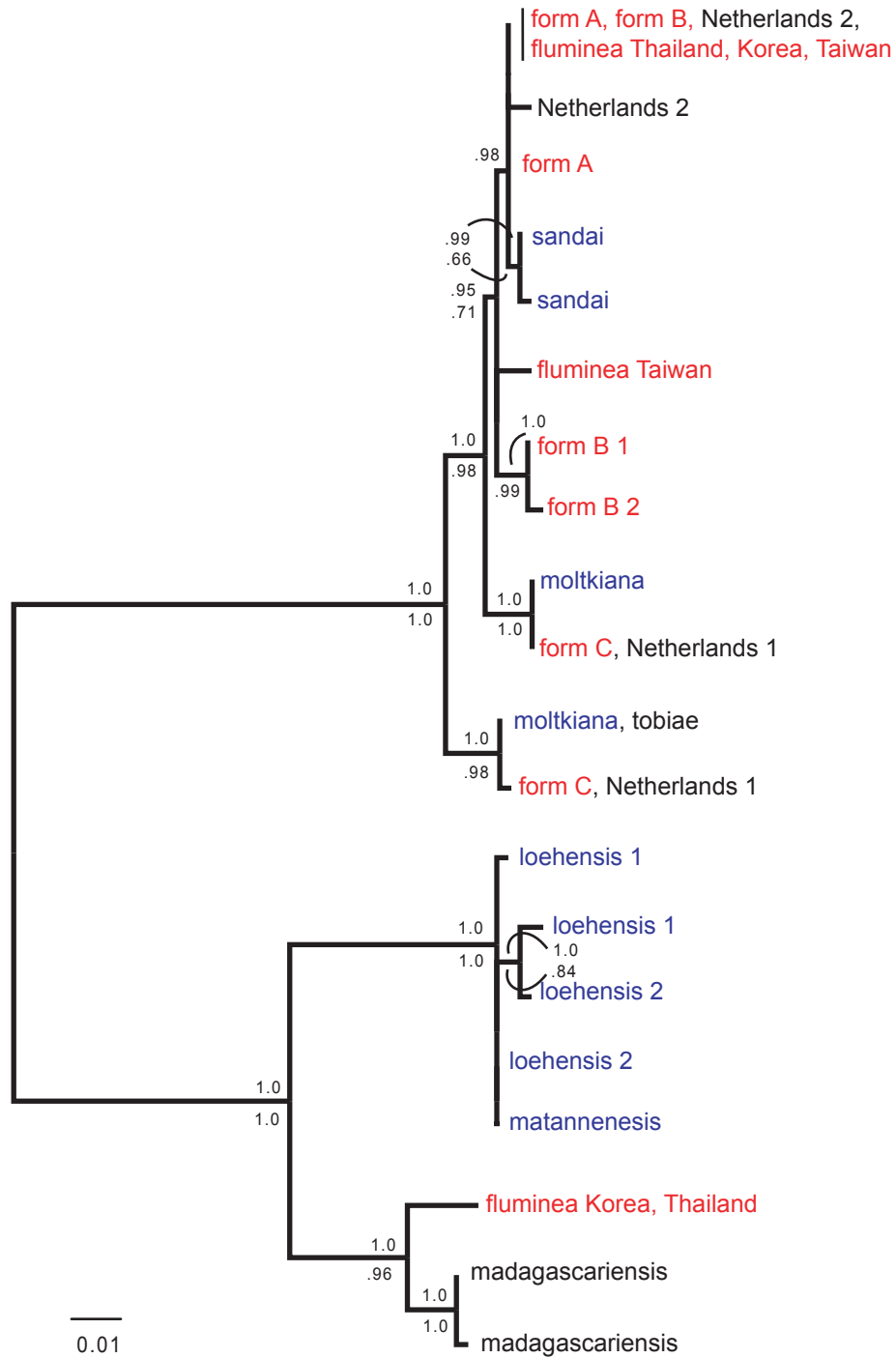

Figure 3.6 Maximum likelihood estimate of the third intron of the nuclear alpha-amylase gene (AMY) using sequences binned by similarity (see text for details). Numbers above the branch indicate Bayesian posterior probabilities, number below are bootstrap proportions. Trees have been rooted with mid-point rooting for visualization.

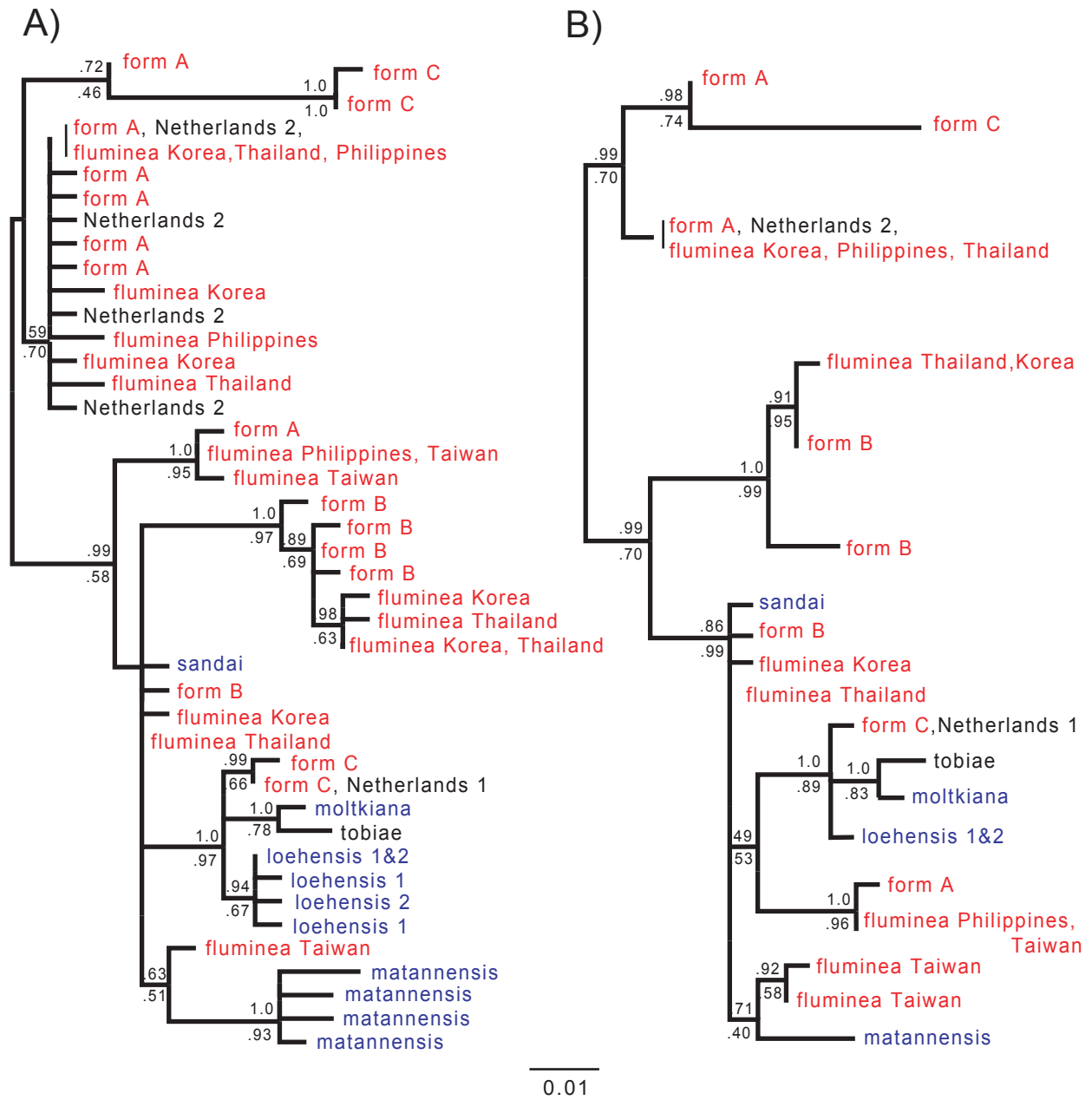

Figure 3.7 Maximum likelihood estimate of a putative nuclear intron of ATPS-alpha (put-ATPS). Red indicates androgenetic species, blue sexual. Numbers above the branch are Bayesian posterior probabilities, numbers below are bootstrap proportions. Trees have been rooted with mid-point rooting for visualization. A) Phylogenetic tree estimated using clone sequence data. B) Phylogenetic tree estimated using sequences binned by similarity (see text for details).

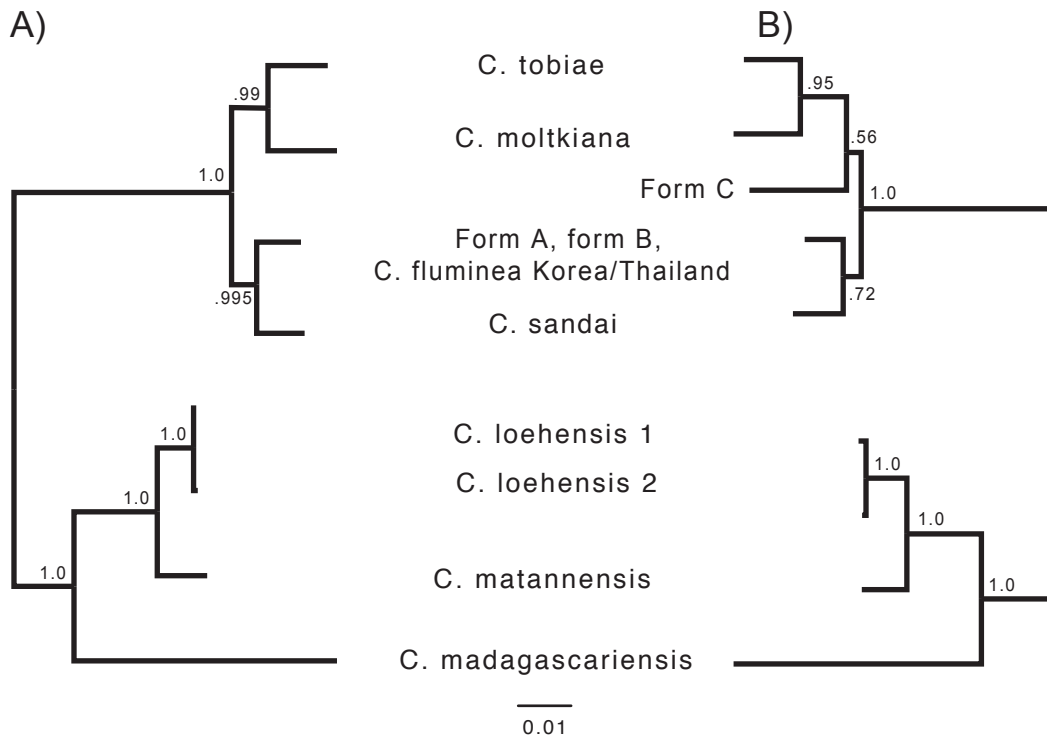

Figure 3.8 Bayesian consensus trees built from concatenated sequences of three markers: COI, AMY, and put-ATPS. Numbers indicate posterior probability of bipartitions. A) Concatenated tree built using common androgenetic sequence (see Methods for details). Topology and support values were identical using androgenetic *C. fluminea*, form A, and form B mitochondrial haplotype sequences. B) Concatenated tree built with the addition of androgenetic form C sequence data.

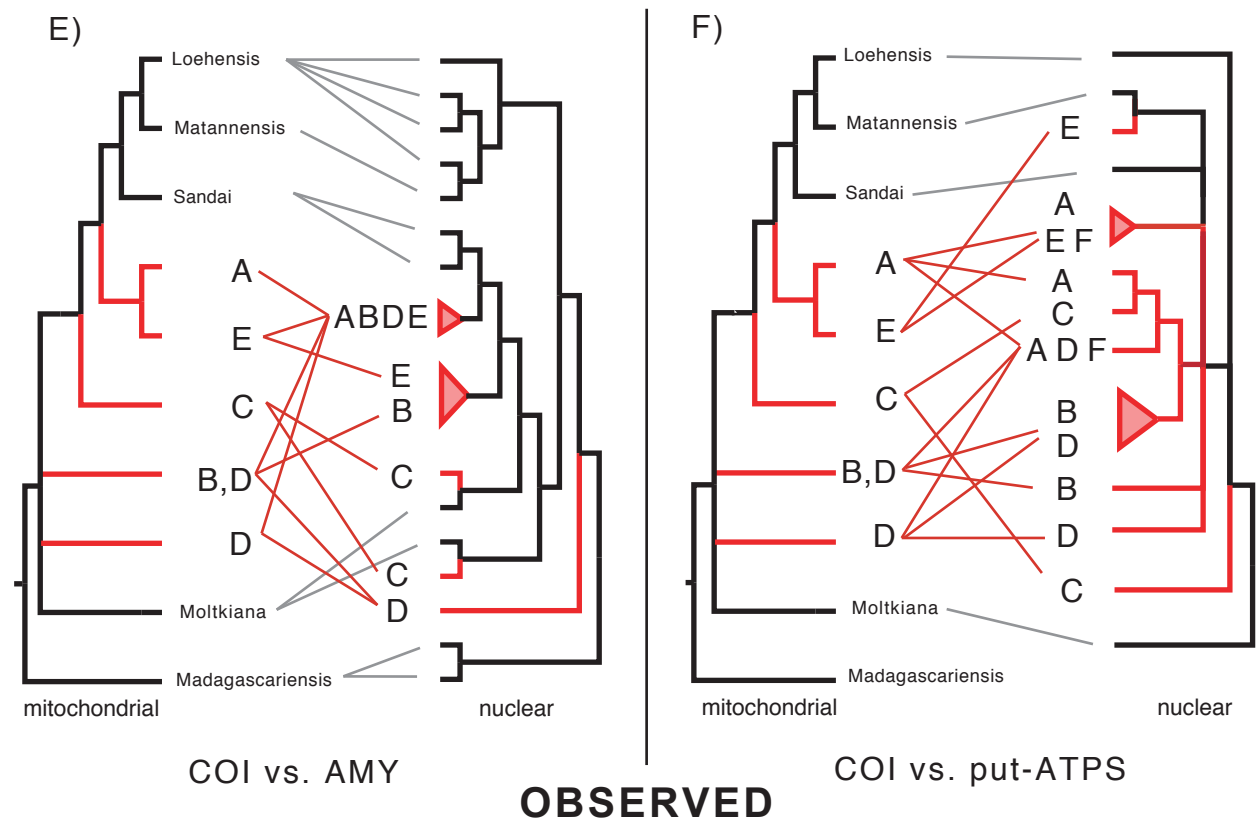
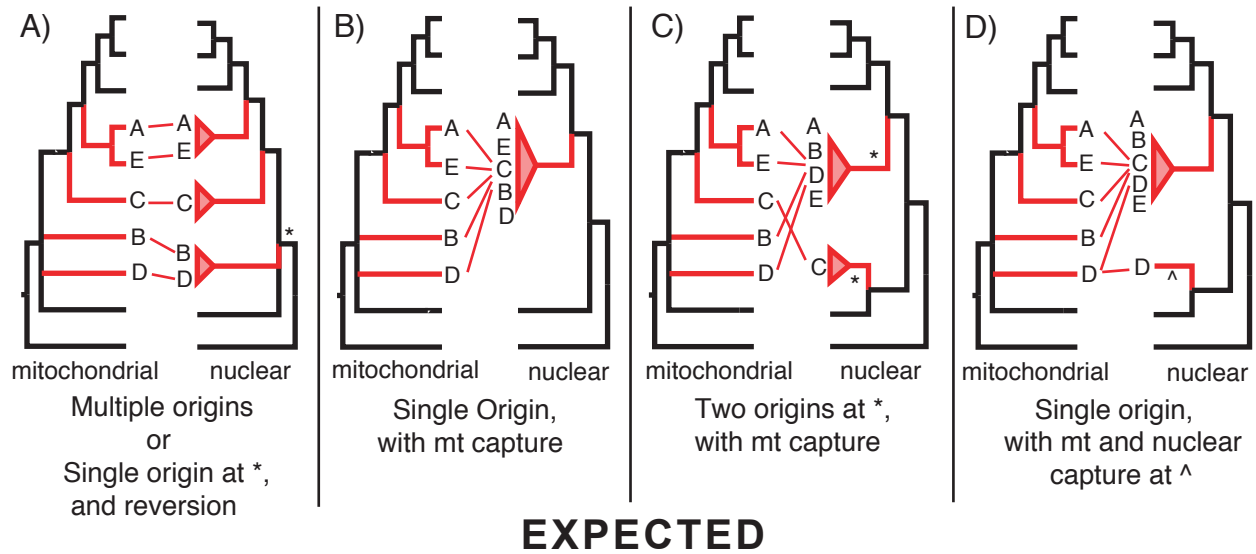

Figure 3.9 The tangled relationships between mitochondrial and nuclear markers in androgenetic *Corbicula*. Central lines between trees indicate where taxa in the mitochondrial tree are found on the nuclear tree. Sexual *Corbicula* are referred to by species name; androgenetic *Corbicula* are in red and referred to by letter for ease of comparison. A: North American form A and Netherlands, B: North American form B, C: South American form C and Netherlands, D: *C. fluminea* Korea and Thailand, E: *C. fluminea* Taiwan, F: *C. fluminea* Philippines. A-D) Expectations for gene tree topologies under four hypotheses given the mitochondrial COI tree. E) Comparison between the mitochondrial COI tree and the nuclear AMY tree. F) Comparison between the mitochondrial COI tree and the nuclear put-ATPS tree.

Chapter 4: The Role of Androgenesis in Cytoplasm Capture

My work has shown that androgenesis is the probable cause of incongruence between nuclear and mitochondrial phylogenies in the clam genus *Corbicula*. I have proposed that this occurs when sperm from an androgenetic clam penetrates the egg of another, divergent species, such that the maternal organelle lineage becomes associated with the paternal nuclear lineage. Androgenesis, however, is not limited to obligately androgenetic systems like *Corbicula*. Facultative (or spontaneous) androgenesis occurs when a paternal lineage which normally reproduces sexually has offspring which have inherited only paternal nuclear DNA. Facultative androgenesis has been observed in multiple plant lineages and in some invertebrates (Table 4.1). Cytoplasm capture (also called mitochondrial or chloroplast capture) occurs when the cytoplasmic organelles of one species are found with the nuclear genome of another species. Capture of maternal cytoplasm after facultative androgenesis has been empirically demonstrated in some laboratory crosses (Goodsell 1961, Chase 1963, Abdalla and Hermsen 1972, Pelletier et al. 1987, Horlow et al. 1993).

In many organisms, gene trees built from nuclear markers and those built using cytoplasmic markers (chloroplasts or mitochondria) infer quite different relationships among the species being studied (e.g., Rieseberg and Soltis 1991, Rieseberg et al. 1996, Cathey et al. 1998, Bergthorsson et al. 2003, Croucher et al. 2004, Sullivan et al. 2004, Fehrer et al. 2007). This incongruence is normally attributed to incomplete lineage sorting (when two alleles coalesce prior to speciation and do not track the

species phylogeny), introgression (interspecific hybridization followed by backcrossing), or horizontal gene transfer via a vector (although conflict can also occur if gene trees do not accurately represent the history of the organisms; see e.g. Wendel and Doyle 1998). For example, mixed stands of North American oaks share chloroplast markers which are fixed by geographical location, rather than by species, and this pattern is attributed to introgression (Whittemore and Schaal 1991), even though hybridization between species is very rare or non-existent (Muller 1961). I propose that androgenesis is another mechanism which could explain cytonuclear incongruence in systems where multiple nuclear markers are concordant (reducing the chance of discordance due to stochastic forces), but in which hybridization is rarely observed between species. If facultative androgenesis occurred between two species, the offspring would have the nuclear genes of the father and the cytoplasmic organelles of the mother. If evolutionary forces such as drift or selection caused the spread of this novel type within a population, the nuclear genes of those individuals sampled would be more closely related to the paternal lineage, while the cytoplasmic genes would group with the maternal lineage (Fig. 4.1).

The cytological and developmental mechanisms which lead to androgenetic reproduction are poorly understood in most systems (clams in the genus *Corbicula* being an exception; Komaru et al. 1998, Ishibashi et al. 2003). However, in those species where facultative androgenesis has been observed, the frequency of androgenetic offspring tends to be higher when the lineages being crossed are more divergent (e.g., Horlow et al. 1993) or when a maternal lineage has a mutation

predisposing eggs to lose the maternal genome (e.g., Komma and Endow 1995). When reciprocal crosses are performed, the frequency of androgenetic offspring can change, indicating that the maternal lineage plays an important role in the generation of paternal clones (e.g. Chen and Heneen 1989, Mantovani and Scali 1992).

The mixed cytonuclear genotypes which result from cytoplasm capture can affect organism phenotype. Reduced male function or even male infertility has been demonstrated due to antagonistic interactions between nuclear and organellar genes (reviewed in Schnable and Wise 1998). Androgenetic offspring from crosses of different potato lineages were male sterile, even though vegetative growth was comparable to that of the parental species, presumably because of interactions between the maternal organelle genomes and paternal nuclear genome (Abdalla and Hermsen 1972). In some mixed cytonuclear genotypes, reduced male function is accompanied by a corresponding increase in female function (Lewis 1941). Rare, spontaneous androgenesis between two dissimilar species could generate a mixed cytonuclear genotype, which could in turn have important evolutionary consequences for the species involved.

ANDROGENESIS AND CYTOPLASM CAPTURE

Models for cytoplasm capture have two main components they need to explain. First, how the organelle from one species moves into the nuclear background of the other, and second, how the novel mixed cytonuclear genotype becomes fixed in a population. I focus my discussion on hermaphrodite or monoecious species, and only consider maternally inherited cytoplasmic organelles. Paternally inherited

organelles would not generate phylogenetic conflict through androgenesis, as the nuclear and cytoplasmic genomes would be inherited together and would share the same history.

Generation of a mixed cytonuclear genotype

Standard models begin with initial hybridization and exchange of nuclear genes between two species (Fig. 4.2A). Subsequent backcrosses of this hybrid need to favor unidirectional nuclear gene flow from the paternal species, with the hybrid as the maternal parent. This could occur through one of the following mechanisms: (1) There is asymmetrical reproductive success (crosses are only successful when one parental lineage is the father and the other is the mother; Rieseberg et al. 1996). (2) A single or few females colonize the region inhabited by the other species (in plants, pollen from the majority species may swamp out pollen from the minority species; Rieseberg et al. 1996). (3) Interactions between cytoplasmic genes from one species and nuclear genes from another give a fitness advantage to the mixed cytonuclear genotype over the paternal species and over nuclear hybrids (Tsitroni et al. 2003). (4) Incompatibilities between nuclear loci select against nuclear hybrids without cytoplasmic interactions (Rieseberg et al. 1996). These mechanisms all require generations to pass before the nuclear genome of the mixed cytonuclear genotype is represented by nuclear alleles from only one of the parental species.

In contrast to the process of introgression described above, androgenesis provides an explanation for how maternal organelles from one species could become associated with the nuclear genome of another in only one generation (Fig. 4.2B). If

facultative androgenesis were initiated when different genotypes or species were crossed, then maternal organelle capture could result when one species fertilized the other. If one of the species were obligately androgenetic, its sperm could steal the eggs of the other species, once again capturing the maternal cytoplasm in one generation. Either way, the incongruence between organelle and nuclear gene trees often attributed to introgression could instead be the result of androgenetic offspring, in which the nuclear genome of one species has displaced that of a second during fertilization while retaining maternal cytoplasmic organelles. For example, semigamy – when two gametes fuse without fusion of nuclear genomes – could have functionally caused facultative androgenesis in an ancestor of *Gossypium bickii*, replacing the original cytoplasm with that of *G. sturtianum* and explaining the current incongruence between nuclear and mitochondrial markers (Wendel et al. 1991). However, since the frequency of cytonuclear hybrids could be low, drift or selection need to be invoked to explain why the genotypes of these offspring go to fixation in a population.

Fixation of mixed cytonuclear type in a population after facultative androgenesis

Models for introgression call for positive selection favoring the novel cytoplasm and nuclear gene combination or for drift to bring the mixed cytonuclear genotype to fixation (e.g. Rieseberg et al. 1996, Tsitrone et al. 2003). These same processes would favor the spread of a mixed cytonuclear genotype regardless of how that genotype was generated – whether through hybridization or through androgenesis. For example, in hermaphrodite species, fixation due to selection of the mixed cytonuclear

genotype after a spontaneous androgenesis event will follow the conditions described by Tsitrone et al. (2003) for cytonuclear heterosis after hybridization. In their single-locus model, fixation of the mixed cytonuclear type occurs if the invading cytoplasm, when paired with the resident nuclear genotype, has a fitness advantage over both the resident cytonuclear genotype and any nuclear hybrids, even when cytoplasmic incompatibilities reduce male fitness.

With selfing species, fixation is facilitated if interactions between resident nuclear alleles and the invading cytoplasm reduce the selfing rate of the mixed cytonuclear genotype, and becomes possible even when cytonuclear interactions do not increase female fitness (Tsitrone et al. 2003). We would also expect these conditions to cause the spread of a mixed cytonuclear genotype when the resident cytoplasm is paired with the invading nuclear genome after androgenesis.

Selection is not required for fixation of a mixed cytonuclear genotype. If the mixed cytonuclear state is neutral or slightly disadvantageous, drift could lead to fixation over time. Rapid boom-bust cycles would speed fixation of the mixed cytonuclear genotype within a population. Assume that mixed cytonuclear genotypes are produced through androgenesis each generation at a frequency of 10%. If the population is reduced to a single individual and then recovers, the new population will be fixed for the mixed cytonuclear genotype 10% of the time, if it is selectively neutral. If it is not fixed in one generation, another 10% of cytonuclear hybrids will be produced the next generation, and the process repeats. But the 10% of the time that

it is fixed, both species within that population will become fixed for the same mitochondrial or chloroplast genomes.

Fixation of the mixed cytonuclear type under obligate androgenesis

If obligate androgenesis arises as a mutation in one species, or as a temporary shift in reproductive mode due to environmental conditions, the conditions for the spread to fixation of the mixed cytonuclear genotype are even less restrictive. Since androgenetic individuals have offspring that carry twice as many paternal alleles as sexual offspring, and assuming that fitness between the two species is otherwise equal, androgenesis – and the mixed cytonuclear genotype – will spread (McKone and Halpern 2003). In hermaphrodite species, even if the mixed cytonuclear genotype imparts partial male sterility, a corresponding increase in female fitness is not required for obligate androgenesis to spread unless male fitness is decreased by more than half (McKone and Halpern 2003).

For example, if two genetically isolated species, *A* and *B*, have incompatible nuclear genomes, no (or only sterile) F1 hybrid offspring would be produced. If a mutation for obligate androgenesis arises in species *A*, then it could use maternal gametes from species *B*. The resulting offspring would be like species *A* in every respect, except that they would have the cytoplasmically inherited organelles of species *B*. Male fitness could be decreased due to cytonuclear incompatibilities between species. Nonetheless, androgenetic individuals could have a far greater overall reproductive output, because they can co-opt the female gametes from the

other species. The mixed cytonuclear genotype could thus spread quickly, since it has become associated with obligate androgenetic reproduction.

If only a single androgenetic individual of species *A* were to disperse into an area occupied by species *B*, and if selfing does not occur, all of the paternal offspring of species *A* would have the mixed cytonuclear type. In this case, androgenetic individuals would not only have a higher reproductive fitness, but would also have a much greater chance of invading a new area. An obligately outcrossing sexual species would require at least two individuals to invade, whereas an outcrossing androgenetic genotype would require only one, and all of its paternal offspring would have the cytonuclear mismatch.

Speed of capture in a natural system

In populations of obligately androgenetic *Corbicula*, cytoplasmic capture through androgenesis has happened rapidly. There are two species of freshwater clams introduced into North American river drainages in the past 80 years (Form A and form B; Counts 1981, 1986). These clams go through regular boom-bust cycles in which large populations are reduced to a very small number of surviving individuals, and then quickly return to a large population size (reviewed in McMahon 1999). Across their North American range, the two species are fixed for different nuclear markers, and no heterozygotes between species-specific alleles have been observed (Hillis and Patton 1982, McLeod 1986, this study Chapter 2). Mixed cytonuclear genotypes occur at low frequency in populations where the two species are found together, with no evidence of hybridization across nuclear loci (Lee et al. 2005;

Chapter 2). I have suggested that cytoplasm capture occurs when the sperm of one species fertilizes the egg of the other species, ejecting the maternal nuclear genome but retaining maternal cytoplasm. Both species spread to the state of Texas only about 30 years ago (Fontanier 1982), and yet in that short period of time, populations in at least one river system have captured and become fixed for the mitochondrial DNA of the other species (Chapter 2).

TESTS FOR ANDROGENESIS

Androgenesis occurs in natural systems and can lead to phylogenetic incongruence between nuclear and cytoplasmic markers. The question is, how often does it occur, and in what systems should we look for it? Unfortunately, for cases in which an organelle capture event occurred in the distant past, it may be difficult to distinguish between possible mechanisms. However, for recent or on-going instances of organelle capture, polymorphisms between populations for cytonuclear mismatch may allow researchers to explore evidence for introgression versus androgenesis. Here, I suggest some ways of determining whether androgenesis could be responsible for cytoplasmic-nuclear gene tree incompatibilities (Table 4.2).

Most other hypotheses for organelle capture assume that introgression causes the emergence of the mixed cytonuclear genotype. This has been documented convincingly in *Helianthus*, which is known to hybridize fairly readily between species (e.g. Rieseberg and Brunsfeld 1992; Rieseberg et al. 1999). However, if cytoplasmic capture is observed between two species but there are no observed nuclear hybrids, cytoplasmic capture may have occurred through androgenesis. For

example, in certain mixed stands of eastern North American white oaks (e.g., *Quercus stellata* and *Q. fusiformis*), F₁ hybrids are unknown in local populations or occur only at very low frequency. If hybrids are formed, they presumably have reduced fitness, as the species remain distinct without forming hybrid swarms (Muller 1961). However, these mixed stands of highly distinctive oaks can be fixed for the same chloroplast markers, even when no hybridization is apparent at a given sampling location (Whittemore and Schaal 1991). This differs from the pattern observed in European oaks, which also form mixed forests but in which hybrid offspring are frequently detected (e.g., Ferris et al. 1993, Petit et al. 1993, Bacilieri et al. 1996). The pattern of chloroplast markers following geographic boundaries rather than species boundaries in North America has been explained by past (unobserved) hybrid introgression (Whittemore and Schaal 1991), but this could be a case of facultative androgenesis between species followed by fixation of the mixed cytonuclear genotype. Facultative androgenesis would not require maintenance of nuclear hybrids with reduced fitness over many generations within a population, as cytoplasm capture (in at least part of the population) would occur in only a single generation. Fixation of the population for the mismatched cytonuclear genotype could then occur through any of the mechanisms described above.

Paternity analyses comparing the nuclear genomes of parents and offspring have detected both facultative and obligate androgenesis in plants and insects (e.g. Komma and Endow 1995, Fournier et al. 2005, Pichot et al. 2001, Pichot et al. 2008). In those cases for which garden experiments or field paternity analyses are possible,

androgenesis could be tested for. Specifically, the presence or absence of paternal and maternal markers could be examined in putatively hybrid offspring. For example, facultative androgenesis has been detected in lab stock crosses in two separate plant genera, *Brassica* and *Zea* (Chase 1963, Chen and Heneen 1989), and natural populations within each genus have been found with chloroplast capture (Palmer et al. 1983, Doebley 1989). Facultative androgenesis may have generated a genotype with a paternal nuclear lineage and a maternal organelle lineage in these populations.

Measurements of the relative fitness of lineages with native and foreign chloroplasts or mitochondria in populations polymorphic for the mixed cytonuclear genotype may reveal possible obligate androgenesis. Selection-based models most effectively explain the rapid fixation of the mixed genotype when the female fitness component or rates of outcrossing are increased (Tsitroni et al. 2003). This fixation is expected when the mixed cytonuclear genotype is generated by either hybrid nuclear introgression or androgenesis. However, if cytonuclear interactions have neutral or slightly deleterious fitness consequences to the female, or no effect on selfing rates, then obligate androgenesis may better explain the spread of the mixed genotype. Obligate androgenesis drives the fixation of cytoplasm capture even when the female component to fitness is lowered (McKone and Halpern 2003). Furthermore, if cytonuclear interactions reduce overall fitness, androgenesis followed by fixation due to drift may explain the data better than a selection-based hypothesis, which requires long-term persistence of backcrossing nuclear hybrids.

FURTHER CONSIDERATIONS AND CONSTRAINTS ON ANDROGENESIS IN PLANTS AND ANIMALS

Facultative and obligate androgenesis are known to occur in both plants and animals. However, there are systems where androgenesis seems very unlikely to generate viable offspring. In dioecious animals with chromosomal sex-determination and male heterogamety (XY), androgenesis with early doubling of the paternal genome may generate inviable zygotes if critical genes are located only on the X chromosome and the fertilizing, haploid sperm carries the Y chromosome (resulting in YY offspring). In systems with female heterogamety (ZW) and maternal inheritance of cytoplasmic organelles, androgenesis will not generate fixed cytonuclear mismatches, because paternal clones will be ZZ males, which do not usually transmit mitochondria or chloroplasts to subsequent generations. Androgenesis will not generate viable offspring in plants and animals with genomic imprinting, as imprinting is likely to cause necessary genes to be turned off on both chromosomes. In addition, the evolution and sweep to fixation of obligate androgenesis in dioecious species is expected to lead to population extinction, as males require females to produce offspring (McKone and Halpern 2003).

Unlike explanations which rely on introgression, my hypothesis for organelle capture by androgenesis does not need to explain why the nuclear genome became represented by the genes of only one species. It only needs to explain the spread of a mixed nuclear and cytoplasmic genotype combination within a population. In organisms with a metapopulation structure characterized by local extirpations and

dispersal, this spread can be explained by stochastic effects of drift and founder events. In the case of invasive species, dispersal into a novel geographic area could also permit rapid fixation of the mixed genotype. Alternatively, the selection-based mechanisms proposed in other models (e.g. Rieseberg et al. 1996, Tsitrone et al. 2003) could cause the spread of this novel genotypic combination.

Androgenesis is commonly ignored as a possible process, so there are no good estimates of how widespread its spontaneous occurrence may be. Androgenesis is obviously not the only – or even the main – force driving phylogenetic incongruence between cytoplasmic and nuclear markers in most biological systems. However, given the known instances of androgenesis in both plants and invertebrates, androgenesis will occur in nature and should be considered as a potential source of phylogenetic incongruence in systems where nuclear hybrids are not observed. Furthermore, the novel cytoplasmic organelle and nuclear genome combination generated by androgenesis could have important phenotypic effects – either positive or negative – and thus affect the evolutionary trajectory of the species' involved.

Table 4.1 Organisms demonstrated to have reproduced through androgenesis. Evidence includes cytological examination of the fertilization process, diagnostic morphological markers (biflagellate sperm in the clam genus *Corbicula*), or determination through phenotypic or genetic markers that only the male parent contributed nuclear genes to the offspring. Estimated frequency should be considered limited to the particular crosses done in a given study and does not necessarily reflect the frequency of androgenesis in the species as a whole.

Organism	Frequency	Evidence	Citation
Obligate androgenesis			
<i>Corbicula australis</i>		morphology	Byrne et al. 2000
<i>Corbicula fluminalis</i>		morphology	Korniushin 2004
<i>Corbicula fluminea</i>	1.0	cytological	Ishibashi et al. 2003
<i>Corbicula leana</i>	1.0	cytological	Komaru et al. 1998
<i>Cupressus dupreziana</i>	1.0	parentage	Pichot et al. 2001
<i>Wasmania auropunctata</i>	1.0	parentage	Fournier et al. 2005
Facultative androgenesis			
<i>Bacillus rossius-grandii benazzii x benazzi</i>	0.01	parentage	Mantovani & Scali 1992
<i>Bacillus rossius-grandii benazzii x maretimi</i>	0.18	parentage	Mantovani & Scali 1992
<i>Bacillus rossius-grandii benazzii x rossius</i>	0.13	parentage	Mantovani & Scali 1992
<i>Brassica napus</i>	0.21*	parentage	Chen & Heneen 1989
<i>Capsicum frutescens</i>		parentage	Campos & Morgan 1958
<i>Drosophila melanogaster</i>	<0.001 to 0.015	parentage	Komma & Endow 1995
<i>Nicotiana debneyi x tabacum</i>	10 ⁻⁴ to 10 ⁻⁵	parentage	Horlow et al. 1993
<i>Nicotiana debneyi-tabacum x tabacum</i>	10 ⁻⁵ to 10 ⁻⁶	parentage	Horlow et al. 1993
<i>Nicotiana suaveolens x tabacum</i>	10 ⁻⁵	parentage	Horlow et al. 1993
<i>Nicotiana tabacum</i>	10 ⁻³	parentage	Burk 1962
	10 ⁻⁴ to 10 ⁻⁶	parentage	Pelletier et al. 1987
	10 ⁻⁵	parentage	Horlow et al. 1993
<i>Solanum verrucosum x andigena</i>	0.09	parentage	Abdalla & Hermsen 1972
<i>Solanum verrucosum x phureja</i>	0.35	parentage	Abdalla & Hermsen 1972
<i>Zea mays</i>		parentage	Goodsell 1961
		parentage	Chase 1963
	0.023	parentage	Kermicle 1969

* reciprocal cross had no androgenetic progeny

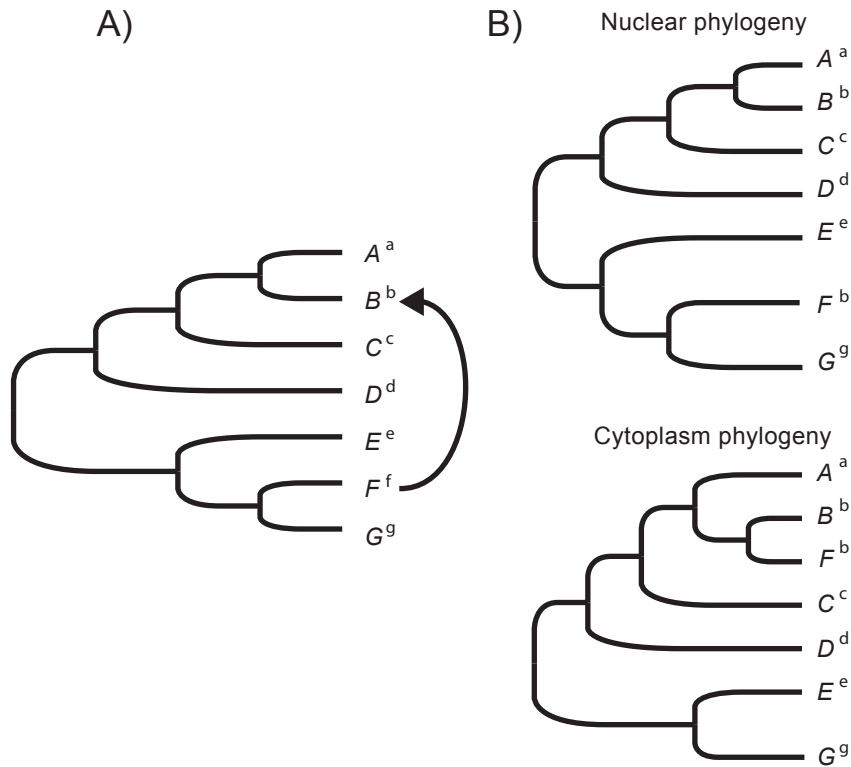
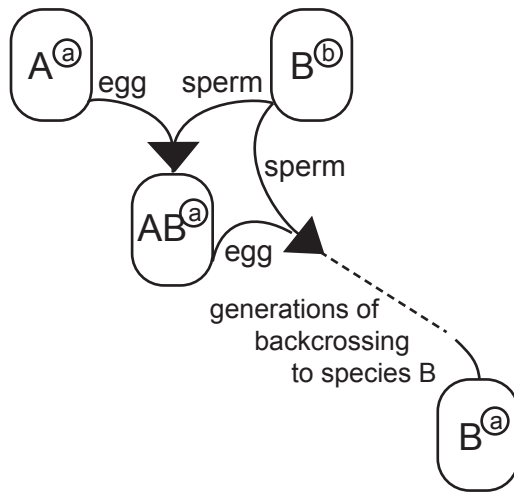

Figure 4.1 Androgenesis can cause phylogenetic discordance between trees built from nuclear versus cytoplasmic markers. Letters in large caps indicate the species' nuclear genome; superscripts indicate the cytoplasmic type. A) Phylogeny detailing relationships between hypothetical species A-G. There is no initial incongruence between nuclear and cytoplasmic trees. Androgenesis arises in species *F*, which then captures the cytoplasm of species *B*. B) The spread of the mixed genotype and extinction of cytoplasmic genome *f* causes incongruence between gene trees; nuclear trees place species *F* as sister to species *G* (as in the initial phylogeny), while cytoplasmic markers place species *F* sister to species *B*.

A) Introgression



B) Androgenesis

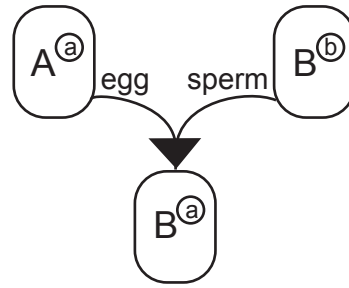

Figure 4.2. Introgression versus androgenesis in cytoplasm capture. Letters in large caps indicate the species' nuclear genome; superscripts indicate the cytoplasmic type. Species *A* serves as the mother and species *B* as the father, and cytoplasmic organelles are maternally inherited. A) Hybridization between two species *A* and *B* creates offspring with nuclear chromosomes from both parents; subsequent backcrossing to species *B* over many generations leads to an individual with the nuclear genome from parent species *B* and the cytoplasmic organelles of species *A*. B) Fertilization of species *A* by species *B* results in offspring with only the paternal nuclear genome. After only one generation this offspring contains the nuclear genome of parent species *B* and the cytoplasmic organelles of species *A*.

References

- Abdalla, M.M.F. and J.G.T. Hermesen. 1972. Diploid parthenogenesis and androgenesis in diploid *Solanum*. *Euphytica* 21:426-431.
- Agrawal, A.F. 2001. Sexual selection and the maintenance of sexual reproduction. *Nature* 411:692-695.
- Agrawal, A. and J.R. Chasnov. 2001. Recessive mutations and the maintenance of sex in structured populations. *Genetics* 158:913-917.
- Antezana, M.A. and R. R. Hudson. 1997. Before crossing over: the advantages of eukaryotic sex in genomes lacking chiasmatic recombination. *Genet. Res. Camb.* 70: 7-25.
- Arnheim, N. 1979. Characterization of mouse ribosomal gene fragments purified by molecular cloning. *Gene* 7:83-96.
- Bacilieri, R., A. Ducouso, R.J. Petit, and A. Kremer. 1996. Mating system and asymmetric hybridization in a mixed stand of European oaks. *Evolution* 50:900-908.
- Barraclough, T.G., C.W. Birky, Jr., and A. Burt. 2003. Diversification in sexual and asexual organisms. *Evolution* 57(9):2166-2172.
- Barton, N.H. 1995. A general model for the evolution of recombination. *Genet. Res.* 65:123-144.
- Barton, N.H. and B. Charlesworth. 1998. Why sex and recombination? *Science* 281:155-160.
- Barton, N.H. and S.P. Otto. 2005. Evolution of recombination due to random drift. *Genetics* 169:2353-2370.
- Bell, G. 1982. *The Masterpiece of Nature: the Evolution and Genetics of Sexuality*. Berkeley: University of California Press.
- Bergthorsson, U., K.L. Adams, B. Thomason, and J.D. Palmer. 2003. Widespread horizontal transfer of mitochondrial genes in flowering plants. *Nature* 424:197-201.
- Birky, C.W., Jr. 1996. Heterozygosity, heteromorphy, and phylogenetic trees in asexual eukaryotes. *Genetics* 144:427-437.
- Birky, C.W., Jr., C. Wolf, H. Maughan, L. Herbertson, and E. Henry. 2005. Speciation and selection without sex. *Hydrobiologia* 546:29-45.
- Bogart, J.P., K. Bi, J. Fu, D.W.A. Noble, and J. Niedzwiecki. 2007. Unisexual salamanders (genus *Ambystoma*) present a new reproductive mode for eukaryotes. *Genome* 50:119-136.
- Boni, M.F., D. Posada, and M.W. Feldman. 2007. An exact nonparametric method for inferring mosaic structure in sequence triplets. *Genetics* 176: 1035-1047.
- Bradley, R.D. and D.M. Hillis. 1997. Recombinant DNA sequences generated by PCR amplification. *Mol. Biol. Evol.* 14:592-593.
- Britton, J.C. and B. Morton. 1979. *Corbicula* in North America: the evidence reviewed and evaluated. *In Proc. First International Corbicula Symposium* (J. C. Britton, ed.), p. 247-287. Texas Christian Univ. Research Foundation, Fort Worth.

- Bromham, L., A. Eyre-Walker, N.H. Smith, and J. Maynard Smith. 2003. Mitochondrial Steve: paternal inheritance of mitochondria in humans. *Trends Ecol. Evol.* 18:2-4.
- Brown, J.M. and A.R. Lemmon. 2007. The importance of data partitioning and the utility of Bayes factors in Bayesian phylogenetics. *Syst. Biol.* 56:643-655.
- Brown, J.M., S.M. Hedtke, A.R. Lemmon, and E.M. Lemmon. When trees grow too long: investigating the causes of highly inaccurate Bayesian branch length estimates. *accepted Syst. Biol.*
- Brown, K.H., R.W. Lee, and G.H. Thorgaard. 2006. Use of androgenesis for estimating maternal and mitochondrial genome effects on development and oxygen consumption in rainbow trout, *Oncorhynchus mykiss*. *Comp. Biochem. Physiol. B: Biochem. Mol. Biol.* 143:415-421.
- Buckler, E.S., A. Ippolito, and T.P. Holtsford. 1997. The evolution of ribosomal DNA: divergent paralogues and phylogenetic implications. *Genetics* 145:821-832.
- Buckley, T. R., M. Cordeiro, D.C. Marshall, and C. Simon. 2006. Differentiating between hypotheses of lineage sorting and introgression in New Zealand Alpine Cicadas (*Maoricicada* Dugdale). *Syst. Biol.* 55(3):411-425.
- Burk, L.G. 1962. Haploids in genetically marked progenies of tobacco. *J. Hered.* 53:222-225.
- Butcher, D. 1995. Muller's ratchet, epistasis and mutation effects. *Genetics* 141: 431-437.
- Butlin, R., I. Schön, and K. Martens. 1998. Asexual reproduction in nonmarine ostracods. *Heredity* 81:473-480.
- Butlin, R. 2006. Comment on 'Transitions to asexuality result in excess amino acid substitutions.' *Science* 318:1389.
- Byrne, M., H. Phelps, T. Church, V. Adair, P. Selvakumaraswamy, and J. Potts. 2000. Reproduction and development of the freshwater clam *Corbicula australis* in southeast Australia. *Hydrobiologia* 418:185-197
- Campos, F.F. and D.T. Morgan, Jr. 1958. Haploid pepper from a sperm: an androgenetic haploid of *Capsicum frutescens*. *J. Hered.* 49:134-137.
- Carstens, B.C. and L.L. Knowles. 2007. Estimating species phylogenies from gene-tree probabilities despite incomplete lineage sorting: an example from *Melanoplus* grasshoppers. *Syst. Biol.* 56:400-411.
- Cathey, J.C., J.W. Bickham, and J.C. Patton. 1998. Introgressive hybridization and nonconcordant evolutionary history of maternal and paternal lineages in North American deer. *Evolution* 52:1224-1229.
- Chao, L. 1990. Fitness of RNA virus decreased by Muller's ratchet. *Nature* 348:454-455.
- Chao, L., T.T. Tran, and T.T. Tran. 1997. The advantage of sex in the RNA virus phi6. *Genetics* 147:953-959.
- Charlesworth, B. 1993. Directional selection and the evolution of sex and recombination. *Genet. Res.* 61:205-224.

- Charlesworth, B. and D. Charlesworth. 1997. Rapid fixation of deleterious alleles can be caused by Muller's ratchet. *Genet. Res., Camb.* 70:63-73.
- Chase, S. S. 1963. Androgenesis – its use for transfer of maize cytoplasm. *J. Hered.* 54:152-158.
- Chasnov, J.R. 2000. Mutation-selection balance, dominance, and the maintenance of sex. *Genetics* 156:1419-1425.
- Chen, B.Y., and W.K. Heneen. 1989. Evidence for spontaneous diploid androgenesis in *Brassica napus* L. *Sex. Plant Reprod.* 2:15-17.
- Cohen, R.R.H., P.V. Dresler, E.J.P. Phillips, and R.L. Cory. 1984. The effect of the Asiatic clam, *Corbicula fluminea*, on phytoplankton of the Potomac River, Maryland. *Limnol. Oceanogr.* 29:170-180.
- Copenhaver, G.P., and C.S. Pikaard. 1996. Two-dimensional RFLP analyses reveal megabase-sized clusters of rRNA gene variants in *Arabidopsis thaliana*, suggesting local spreading of variants as the mode for gene homogenization during concerted evolution. *Plant J.* 9:273-282.
- Counts, C.L., III. 1981. *Corbicula fluminea* (Bivalvia: Sphaeriacea) in British Columbia. *Nautilus* 95:12-13.
- Counts, C. L., III. 1986. The zoogeography and history of the invasion of the United States by *Corbicula fluminea* (Bivalvia: Corbiculidae). *Am. Malacol. Bull. Special Ed. No. 2*:7-39.
- Crease, T.J. and M. Lynch. 1991. Ribosomal DNA variation in *Daphnia pulex*. *Mol. Bio. Evol.* 8:620-640.
- Croucher, P.J.P., G.S. Oxford, and J.B. Searle. 2004. Mitochondrial differentiation, introgression and phylogeny of species in the *Tegenaria atrica* group (Araneae: Agelenidae). *Biol. J. Linn. Soc.* 81:79-89.
- Crow, J.F. and M. Kimura. 1965. Evolution in sexual and asexual populations. *Am. Nat.* 99: 439-450.
- Dahlgren, T.G., J.R. Weinberg, and K.M. Halanych. 2000. Phylogeography of the ocean quahog (*Arctica islandica*): influences of paleoclimate on genetic diversity and species range. *Marine Biol.* 137:487-495.
- Datta, S.K. 2005. Androgenetic haploids: factors controlling development and its application in crop improvement. *Curr. Sci.* 89:1870-1878.
- Dawley, R.M. 1989. An introduction to unisexual vertebrates. In *Evolution and Ecology of Unisexual Vertebrates* (R.M. Dawley and J.P. Bogart, eds), pp. 1–18. Albany, NY: New York State Museum.
- Doebly, J.F. 1989. Molecular evidence for a missing wild relative of maize and introgression of its chloroplast genome into *Zea perennis*. *Evolution* 43:1555-1558.
- Drake, J.W. 1991. A constant rate of spontaneous mutation in DNA-based microbes. *Proc. Nat. Acad. Sci. USA* 88:7160-7164.
- Dries, L.A. 2000. The evolutionary persistence of the gynogenetic Amazon molly, *Poecilia formosa*. PhD dissertation, the University of Texas at Austin.

- Dries, L.A. 2003. Peering through the looking glass: are Amazon mollies red queens? *Evolution* 57(6):1387-96.
- Dybdahl, M.F. and C.M. Lively. 1998. Host-parasite coevolution: evidence for rare advantage and time-lagged selection in natural populations. *Evolution* 52:1057-1066.
- Elena, S.F. and R.E. Lenski. 1997. Long term experimental evolution in *Escherichia coli* VII. Mechanisms maintaining genetic variability within populations. *Evolution* 51:1059-1067.
- Escarmís, C, M. Dávila, N. Charpentier, A. Bracho, A. Moya, and E. Domingo. 1996. Genetic lesions associated with Muller's Ratchet in an RNA virus. *J. Mol. Bio.* 264:255-267.
- Feliner, G.N., B.G. Larena, and J.F. Aguilar. 2004. Fine-scale geographical structure, intra-individual polymorphism and recombination in nuclear ribosomal internal transcribed spacers in *Armeria* (Plumbaginaceae). *Ann. Bot.* 93:189-200.
- Felsenstein, J. 1974. The evolutionary advantage of recombination. *Genetics* 78:737-756.
- Fehrer, J., B. Gemeinholzer, J. Chrtek, Jr., and S. Bräutigam. 2007. Incongruent plastid and nuclear DNA phylogenies reveal ancient intergeneric hybridization in *Pilosella* hawkweeds (*Hieracium*, Cichorieae, Asteraceae). *Mol. Phyl. Evol.* 42:347-361.
- Ferris, C., R.P. Oliver, A.J. Davy, and G.M. Hewitt. 1993. Native oak chloroplasts reveal an ancient divide across Europe. *Mol. Ecol.* 2:337-344.
- Fisher, R.A. 1930. *The Genetical Theory of Natural Selection*. Oxford: Clarendon Press.
- Fisher, C., and D. O. F. Skibinski. 1990. Sex-biased mitochondrial DNA heteroplasmy in the marine mussel *Mytilus*. *Proc. R. Soc. Lond., Ser. B: Biol. Sci.* 242:149-156.
- Folmer, O., M. Black, W. Hoeh, R. Lutz, and R. Vrijenhoek. 1994. DNA primers for amplification of mitochondrial cytochrome c oxidase subunit I from diverse metazoan invertebrates. *Mol. Mar. Biol. Biotechnol.* 3:294-9.
- Fontaneto, D., E.A. Herniou, C. Boschetti, M. Caprioli, G. Melone, C. Ricci, and T.G. Barraclough. 2007. Independently evolving species in asexual bdelloid rotifers. *PLOS Biol.* 5(4):914-921.
- Fontanier, C.E. 1982. The distribution of *Corbicula* (Bivalvia: Corbiculidae) in the Brazos River system, Texas, 25 August-12 November 1980. *Texas J. Sci.* 34:5-15.
- Foucoud, J., H. Jourdan, J. le Breton, A. Loiseau, D. Konghouleux, and A. Estoup. 2006. Rare sexual reproduction events in the clonal reproduction system of introduced populations of the little fire ant. *Evolution* 60(8):1646-1657.
- Fournier, D., A. Estoup, R.M. Orivel, J. Foucaud, H. Jourdan, J. Le Breton, and L. Keller. 2005. Clonal reproduction by males and females in the little fire ant. *Nature* 435:1230-4.

- Fuller, S.L.H., and M.J. Imlay. 1976. Spatial competition between *Corbicula manilensis* (Philippi), the Chinese clam (Corbiculidae), and fresh-water mussels (Unionidae) in the Waccamaw River basin of the Carolinas (Mollusca: Bivalvia). *Assoc. Southeast. Biologists Bull.* 23:60.
- Gabriel, W., M. Lynch, and R. Bürger. 1993. Muller's ratchet and mutational meltdowns. *Evolution* 47:1744-1752.
- Gard, D.L., B.-J. Cha, and A.D. Roeder. 1995. F-actin is required for spindle anchoring and rotation in *Xenopus* oocytes: a re-examination of the effects of cytochalasin B on oocyte maturation. *Zygote* 3: 17–26.
- Gandolfi, A., P. Bonilauri, V. Rossi, and P. Menozzi. 2001. Intraindividual and intraspecies variability of ITS1 sequences in the ancient asexual *Darwinula stevensoni* (Crustacea: Ostracoda). *Heredity* 87:449-455.
- Gerrish, P.J. and R.E. Lenski. 1998. The fate of competing beneficial mutations in an asexual population. *Genetica* 102/103:127-144.
- Gibbs, M.J., J.S. Armstrong, and A.J. Gibbs. 2000. Sister-Scanning: a Monte Carlo procedure for assessing signals in recombinant sequences. *Bioinf.* 16: 573-582.
- Gladyshev, E. and M. Meselson. 2008. Extreme resistance of bdelloid rotifers to ionizing radiation. *PNAS* 105:5139-5144.
- Glaubrecht, M., T.V. Rintelen, and A.V. Korniushev. 2003. Toward a systematic revision of brooding freshwater Corbiculidae in southeast Asia (Bivalvia, Veneroidea): on shell morphology, anatomy and molecular phylogenetics of endemic taxa from islands in Indonesia. *Malacologia* 45:1-40.
- Goddard, M.R., H.C J. Godfray, and A. Burt. 2005. Sex increases the efficacy of natural selection in experimental yeast populations. *Nature* 434:636-640.
- Goodsell, S. F. 1961. Male sterility in corn by androgenesis. *Crop. Sci.* 1:227-228.
- Green, R.F. and D.L.G. Noakes. 1995. Is a little bit of sex as good as a lot? *J. Theor. Biol.* 174:87-96.
- Grunina, A.S. and A.V. Recoubratsky. 2005. Induced androgenesis in fish: obtaining viable nucleocytoplasmic hybrids. *Russ. J. Dev. Biol.* 36:208-217.
- Gyllenstein, U., D. Wharton, A. Josefsson, and A. C. Wilson. 1991. Paternal inheritance of mitochondrial DNA in mice. *Nature* 352:255-7.
- Haccou, P. and M.V. Schneider. 2004. Modes of reproduction and the accumulation of deleterious mutations with multiplicative fitness effects. *Genetics* 166:1093-1104.
- Hasimoto, H. 1934. Formation of an individual by the union of two sperm nuclei in the silkworm. *Bull. Seric. exp. Stn Jap.* 8 (10): 455-464.
- Hedges, S.B., J.P. Bogart, and L.R. Maxson. 1992. Ancestry of unisexual salamanders. *Nature* 356:708-710.
- Hedtke, S.M., T.M. Townsend, and D.M. Hillis. 2006. Resolution of phylogenetic conflict in large data sets by increased taxon sampling. *Syst. Biol.* 55(3):522-529.
- Hill, W.G. and A. Robertson. 1966. The effect of linkage on limits to artificial selection. *Genet. Res.* 8:269-294.

- Hillis, D.M. 2007. Asexual evolution: can species exist without sex? *Current Biol.* 17(14):R543-4.
- Hillis, D.M. and M.T. Dixon. 1991. Ribosomal DNA: molecular evolution and phylogenetic inference. *Q. Rev. Biol.* 66:411-453.
- Hillis, D.M., B.K. Mable, A. Larson, S.K. Davis, and E.A. Zimmer. 1996. Nucleic acids IV: Sequencing and cloning. Pp. 321-381 in. *Molecular Systematics* (D.M. Hillis, B.K. Mable and C. Moritz, eds). Sinauer, Sunderland, Massachusetts.
- Hillis, D. M. and J. C. Patton. 1982. Morphological and electrophoretic evidence for two species of *Corbicula* (Bivalvia: Corbiculidae) in North America. *Am. Midl. Nat.* 108:74-80.
- Horlow, C., M.C. Defrance, J.M. Pollien, J. Goujaud, R. Delon, and G. Pelletier. 1993. Transfer of cytoplasmic male sterility by spontaneous androgenesis in tobacco (*Nicotiana tabacum* L.). *Euphytica* 66:45-53.
- Hubbs, C. 1964. Interactions between a bisexual fish species and its gynogenetic sexual parasite. Bulletin 8 Texas Memorial Museum, Austin.
- Hugall, A., J. Stanton, and C. Moritz. 1999. Reticulate evolution and the origins of ribosomal internal transcribed spacer diversity in apomictic Meloidogyne. *Mol. Biol. Evol.* 16:157-164.
- Hurst, L.D. and J.R. Peck. 1996. Recent advances in understanding of the evolution and maintenance of sex. *Trends Ecol. Evol.* 11:46-52.
- Innes, D.J. and P.D.N. Hebert. 1988. The origin and genetic basis of obligate parthenogenesis in *Daphnia pulex*. *Evolution* 42(5):1024-1035.
- Ishibashi, R., A. Komaru, K. Ookubo, and M. Kiyomoto. 2002. The second meiosis occurs in cytochalasin D-treated eggs of *Corbicula leana* even though it is not observed in control androgenetic eggs because the maternal chromosomes and centrosomes are extruded at first meiosis. *Dev. Biol.* 244:37-43.
- Ishibashi, R., K. Ookubo, M. Aoki, M. Utaki, A. Komaru, and K. Kawamura. 2003. Androgenetic reproduction in a freshwater diploid clam *Corbicula fluminea* (Bivalvia: Corbiculidae). *Zool. Sci.* 20:727-732.
- Ishibashi, R. and A. Komaru. 2006. Abortive second meiosis detected in cytochalasin-treated eggs in androgenetic diploid *Corbicula fluminea*. *Develop. Growth Differ.* 48:277-282.
- Isom, B. G. 1986. Historical review of Asiatic clam (*Corbicula*) invasion and biofouling of waters and industries in the Americas. *Am. Malacol. Bull. Special Ed. No. 2*:1-5.
- Jarman, S.N., R.D. Ward, and N.G. Elliot. 2002. Oligonucleotide primers for PCR amplification of coelomate introns. *Marine Biotech.* 4:347-355.
- Jasnos, L. and R. Korona. 2007. Epistatic buffering of fitness loss in yeast double deletion strains. *Nature Genetics* 39(4):550-554.
- Johnson, S.G. and E. Bragg. 1999. Age and polyphyletic origins of hybrid and spontaneous parthenogenetic *Campeloma* (Gastropoda: Viviparidae) from the southeastern United States. *Evolution* 53(6):1769-1781.

- Jokela, J., and C.M. Lively. 1995. Spatial variation for infection by digenetic trematodes in a population of freshwater snails (*Potamopyrgus antipodarum*). *Oecologia* 103:509-517.
- Judson, O.P. and B.B. Normark. 1996. Ancient asexual scandals. *Trends Evol. Ecol.* 11(2):41-46.
- Karpen, G.H., and S.A. Endow. 1998. Meiosis: chromosome behavior and spindle dynamics. Pp. 203–247 *in* Dynamics of Cell Division (S.A. Endow and D.M. Glover, eds.). Oxford: Oxford Univ. Press.
- Keller, I., I.C. Chintauan-Marquier, P. Veltsos, and R.A. Nichols. 2006. Ribosomal DNA in the grasshopper *Podisma pedestris*: escape from concerted evolution. *Genetics* 174:863-874.
- Kermicle, J.L. 1969. Androgenesis conditioned by a mutation in maize. *Science* 166:1422-1424.
- Kirkpatrick M. and C.D. Jenkins. 1989. Genetic segregation and the maintenance of sex. *Nature* 339:300-301.
- Kobayashi, N., K. Tamura, and T. Aotsuka. 1999. PCR error and molecular population genetics. *Biochem. Genet.* 37:317-321.
- Komaru, A., K. Konishi, I. Nakayama, T. Kobayashi, H. Sakai, and K. Kawamura. 1997. Hermaphroditic freshwater clams in the genus *Corbicula* produce non-reductional spermatozoa with somatic DNA content. *Biol. Bull.* 193:320-323.
- Komaru, A., T. Kawagishi, and K. Konishi. 1998. Cytological evidence of spontaneous androgenesis in the freshwater clam *Corbicula leana* Prime. *Dev. Genes Evol.* 208:46-50.
- Komaru, A., and K. Konishi. 1999. Non-reductional spermatozoa in three shell color types of the freshwater clam *Corbicula fluminea* in Taiwan. *Zool. Sci.* 16:105-108.
- Komaru, A., K. Ookubo, and M. Kiyomoto. 2000. All meiotic chromosomes and both centrosomes at spindle pole in the zygotes discarded as two polar bodies in clam *Corbicula leana*: unusual polar body formation observed by antitubulin immunofluorescence. *Dev. Genes Evol.* 210:263-269.
- Komaru, A., A. Kumamoto, and R. Ishibashi. 2001. Possible elevation of ploidy levels by accidental formation of female pronucleus in androgenetic clam *Corbicula leana*. *Dev. Biol.* 18:87.
- Komaru, A., A. Kumamoto, T. Kato, R. Ishibashi, M. Obata, and T. Nemoto. 2006. A hypothesis of ploidy elevation by formation of a female pronucleus in the androgenetic clam *Corbicula fluminea* in the Tone River Estuary, Japan. *Zool. Sci.* 23:529-532.
- Komma, D.J., and S.A. Endow. 1995. Haploidy and androgenesis in *Drosophila*. *Proc. Natl. Acad. Sci. USA* 92:11884-8.
- Kondo, R., Y. Satta, E.T. Matsuura, H. Ishiwa, N. Takahata, and S.I. Chigusa. 1990. Incomplete maternal transmission of mitochondrial DNA in *Drosophila*. *Genetics* 126:657-63.

- Kondrashov, A.S. 1982. Selection against harmful mutations in large sexual and asexual populations. *Genet. Res.* 40:325-332.
- Kondrashov, A.S. 1984. Deleterious mutations as an evolutionary factor in the advantage of recombination. *Genet. Res.* 44:199-217.
- Kondrashov, A.S. 1988. Deleterious mutations and the evolution of sexual reproduction. *Nature* 335:435-440.
- Kondrashov, A.S. 1994. Muller's ratchet under epistatic selection. *Genetics* 136:1469-1473.
- Konishi, K., K. Kawamura, H. Furuita, and A. Komaru. 1998. Spermatogenesis of the freshwater clam *Corbicula aff. fluminea* Müller (Bivalvia: Corbiculidae). *J. Shellfish Res.* 17:185-189.
- Korniushin, A.V. 2004. A revision of some Asian and African freshwater clams assigned to *Corbicula fluminalis* (Müller, 1974) (Mollusca: Bivalvia: Corbiculidae), with a review of anatomical characters and reproductive features based on museum collections. *Hydrobiologia* 529:251-270.
- Korniushin, A.V., and M. Glaubrecht. 2003. Novel reproductive modes in freshwater clams: brooding and larval morphology in Southeast Asian taxa of *Corbicula* (Mollusca, Bivalvia, Corbiculidae). *Acta Zoologica(Stockholm)* 84: 293–315.
- Kraemer, L.R. 1978. *Corbicula fluminea* (Bivalvia: Sphaeriacea): the functional morphology of its hermaphroditism. *Bull. Am. Malacol. Union* 1978:40-49.
- Kraemer, L.R., C. Swanson, M. Galloway, and R. Kraemer. 1986. Biological basis of behavior in *Corbicula fluminea*, II. Functional morphology of reproduction and development and review of evidence for self-fertilization. *Am. Malacol. Bull. Special Ed. No. 2*:193-201.
- Lamatsch, D.K., M. Schmid, and M. Scharl. 2002. Somatic mosaic of the gynogenetic Amazon molly, *P. formosa* (Poeciliidae, Teleostei). *J. Fish. Biol.* 60:1417-1422.
- Lamatsch, D.K., I. Nanda, I. Schupp, J.T. Epplen, M. Schmid, and M. Scharl. 2004. Distribution and stability of supernumerary microchromosomes in natural populations of the Amazon molly, *Poecilia formosa*. *Cytogenetics and Genome Res.* 106:189-194.
- Lewis, D.G. 1941. Male sterility in natural populations of hermaphrodite plants. *New Phytol.* 40:56-63.
- Lewontin, R.C. and K. Kojima. 1960. The evolutionary dynamics of complex polymorphisms. *Evolution* 14:458-472.
- Lee, T., S. Siripattawan, C.F. Ituarte, and D. Ó Foighil. 2005. Invasion of the clonal clams: *Corbicula* lineages in the New World. *Am. Malac. Bull.* 20:113-122.
- Lenormand, T. and S.P. Otto. 2000. The evolution of recombination in a heterogeneous environment. *Genetics* 156:423-438.
- Lim, K.Y., A. Kovarik, R. Matyasek, M. Bezdek, C.P. Lichtenstein, and A.R. Leitch. 2000. Gene conversion of ribosomal DNA in *Nicotiana tabacum* is associated with undermethylated, decondensed and probably active gene units. *Chromosoma* 109:161-172.

- Little, T.J. and P.D.N. Hebert. 1996. Ancient asexuals: scandal or artifact? *Trends Ecol. Evol.* 11(7):296.
- Liu, H., J.B. Mitton and S. Wu. 1996. Paternal mitochondrial DNA differentiation far exceeds maternal mitochondrial DNA and allozyme differentiation in the freshwater mussel, *Anodonta grandis grandis*. *Evolution* 50: 952–957.
- Liu, L., and D.K. Pearl. 2007. Species trees from gene trees: reconstructing Bayesian posterior distributions of a species phylogeny using estimated gene tree distributions. *Syst. Biol.* 56:504–514.
- Loewe, L. and D.K. Lamatsch. 2008. Quantifying the threat of extinction from Muller's ratchet in the diploid Amazon molly (*Poecilia formosa*). *BMC Evol. Biol.* 8:88.
- Lynch, M. 1996. Mutation accumulation in transfer RNAs: molecular evidence for Muller's ratchet in mitochondrial genomes. *Mol. Biol. Evol.* 13:209-220.
- Lynch, M. and J.L. Blanchard. 1998. Deleterious mutation accumulation in organelle genomes. *Genetica* 102/103:29-39.
- Lynch, M., R. Bürger, D. Butcher, and W. Gabriel. 1993. Mutational meltdown in asexual populations. *J. Hered.* 84:339-344.
- Lynch, M. and W. Gabriel. 1990. Mutation load and the survival of small populations. *Evolution* 44: 1725-1737.
- Mable, B.K. 2007. Sex in the postgenomic era. *Trends Ecol. Evol.* 22:559-561.
- Maddison, W.P. 1997. Gene tree in species trees. *Syst. Biol.* 46:523-536.
- Maddison, D.R. and W.P. Maddison. 2000. *MacClade 4*. Sinauer Associates, Inc., Sunderland, Massachusetts.
- Mantovani, B. and V. Scali. 1992. Hybridogenesis and androgenesis in the stick-insect *Bacillus rossius-grandis benazzii* (Insecta, Phasmatodea). *Evolution* 46:783-796.
- Mark Welch, D.B., M.P. Cummings, D.M. Hillis, and M. Meselson. 2004. Divergent gene copies in the asexual class Bdelloidea (Rotifera) separated before the bdelloid radiation or within bdelloid families. *PNAS* 101:1622-1625.
- Mark Welch, D.B. and M.J. Meselson. 2001. Rates of nucleotide substitution in sexual and anciently asexual rotifers. *Proc. Natl. Acad. Sci. USA* 98(12):6720-6724.
- Martin, D. and E. Rybicki. 2000. RDP: detection of recombination amongst aligned sequences. *Bioinformatics* 16, 562-563.
- Martin, D.P., D. Posada, K.A. Crandall, and C. Williamson. 2005a. A modified bootscan algorithm for automated identification of recombinant sequences and recombination breakpoints. *AIDS Res Hum Retroviruses* 21, 98-102/
- Martin, D.P., C. Williamson, and D. Posada. 2005b. RDP2: recombination detection and analysis from sequence alignments. *Bioinformatics* 21, 260-262.
- Martin, G., S.P. Otto, and T. Lenormand. 2006. Selection for recombination in structured populations. *Genetics* 172:593-609.
- Maynard Smith, J. 1978. *The Evolution of Sex*. Cambridge: Cambridge University Press.

- Maynard Smith, J. 1989. The evolution of genetic systems I. Sex and recombination. pp. 231-254 in *Evolutionary Genetics*. Oxford: Oxford University Press.
- Maynard Smith, J. 1992. Analyzing the mosaic structure of genes. *J. Mol. Evol.* 34:126-129.
- McKone, M.J., and S.L. Halpern. 2003. The evolution of androgenesis. *Am. Nat.* 161:641-656.
- McLeod, M. J. 1986. Electrophoretic variation in North American *Corbicula*. *Am. Malacol. Bull. Special Ed. No. 2*:125-132.
- McMahon, R.F. 1982. The occurrence and spread of the introduced Asiatic freshwater clam, *Corbicula fluminea* (Müller), in North America: 1924-1982. *Nautilus* 96:134-141.
- McMahon, R. F. 1999. Invasive characteristics of the freshwater bivalve *Corbicula fluminea*. Pp. 315-342 in *Nonindigenous Freshwater Organisms: Vectors, Biology, and Impacts* (R. Claudi and J. H. Leach, eds.). Lewis Publishers, Boca Raton, FL.
- Merritt, T.J.S., L. Shi, M.C. Chase, M.A. Rex, R.J. Etter, and J.M. Quattro. 1998. Universal cytochrome b primers facilitate intraspecific studies in molluscan taxa. *Mol. Marine Biol. Biotech.* 7:7-11.
- Mes, T.H.M. and A.W.C.A. Cornelissen. 2004. Non-homogenized ITS regions in the parasitic nematode *Cooperia oncophora*. *Parasitology* 129:213-222.
- Mindell, D.P. and C.E. Thacker. 1996. Rates of molecular evolution: phylogenetic issues and applications. *Annu. Rev. Ecol. Syst.* 27:279-303.
- Mizi, A. E. Zouros, N. Moschonas, and G. C. Rodakis. 2005. The complete maternal and paternal genomes of the Mediterranean mussel *Mytilus galloprovincialis*: implications for the doubly uniparental inheritance mode of mtDNA. *Mol. Biol. Evol.* 22:952-967.
- Moritz, C. 1983. Parthenogenesis in the endemic Australian lizard *Heteronotia binoei* (Gekkonidae). *Science* 220:735-737.
- Moritz, C. and A. Heideman. 1993. The origin and evolution of parthenogenesis in *Heteronotia binoei* (Gekkonidae): reciprocal origins and diverse mitochondrial DNA in western populations. *Syst. Biol.* 42(3):293-306.
- Morton, B. 1986. *Corbicula* in Asia – an updated synthesis. *Am. Malac. Bull., Sp. Ed.* No. 2:113-124.
- Moyzis, R.K., K.L. Albright, M.F. Bartholdi, L.S. Cram, L.L. Deaven, C.E. Hildebrand, N.E. Joste, J.L. Longmire, J. Meyne, and T. Schwarzacher-Robinson. 1987. Human chromosome-specific repetitive DNA sequences: novel markers for genetic analysis. *Chromosoma* 95:375-386.
- Muir, G., C.C. Fleming, and C. Schlütterer. 2001. Three divergent rDNA clusters predate the species divergence in *Quercus petraea* (Matt.) Leibl. and *Quercus robur* L. *Mol. Biol. Evol.* 18:112-119.
- Muller, C.H. 1961. The live oaks of the series *Virentes*. *Am. Midl. Nat.* 65:17-39.
- Muller, H.J. 1932. Some genetic aspects of sex. *Am. Nat.* 66:118-138.

- Muller, H.J. 1964. The relation of recombination to mutational advance. *Mutat. Res.* 1:2-9.
- Nanda, I., I. Schlupp, D.K. Lamatsch, K.P. Lampert, M. Schmid, and M. Schartl. 2007. Stable inheritance of host species-derived microchromosomes in the gynogenetic fish, *Poecilia formosa*. *Genetics* 177:917-921.
- Nei, M. 1970. Accumulation of nonfunctional genes on sheltered chromosomes. *Am. Nat.* 104:311-322.
- Normark, B.B. 1999. Evolution in a putatively ancient asexual aphid lineage: recombination and rapid karyotypic change. *Evolution* 53:1458-1469.
- Normark, B.B., O.P. Judson, and N.A. Moran. 2003. Genomic signatures of ancient asexual lineages. *Biol. J. Linnean Soc.* 79:69-84.
- Nylander, J.A.A. 2004. MrModelTest v2. Program distributed by the author. Evolutionary Biology Centre, Uppsala University.
- Ó Foighil, D. and M.J. Smith. 1995. Evolution of asexuality in the cosmopolitan marine clam *Lasaea*. *Evolution* 49(1):140-150.
- Okamoto, A., and B. Arimoto. 1986. Chromosomes of *Corbicula japonica*, *C. sandai* and *C. (Corbiculina) leana* (Bivalvia: Corbiculidae). *Venus Jap. J. Malacol.* 45:194-202.
- Otto, S.P. and N. Barton. 1997. The evolution of recombination: removing the limits to natural selection. *Genetics* 147:879-906.
- Padidam, M., S. Sawyer, and C.M. Fauquet, 1999. Possible emergence of new geminiviruses by frequent recombination. *Virology* 265, 218-225.
- Palumbi, S.R. 1996. Nucleic acids II: the polymerase chain reaction. Pp. 205-247 in *Molecular Systematics* (D.M. Hillis, C. Moritz, and B.K. Mable, eds.). Sunderland: Sinauer Assoc., Inc.
- Page, R.D.M. and M. A. Charleston. 1998. Trees within trees: phylogeny and historical associations. *Trends. Ecol. Evol* 13:9356-359.
- Paland, S. and M. Lynch. 2006. Transitions to asexuality result in excess amino acid substitutions. *Science* 311:990-992.
- Paland, S., J.K. Colbourne, and M. Lynch. 2005. Evolutionary history of contagious asexuality in *Daphnia pulex*. *Evolution* 59:800-813.
- Palmer, J.D., C.R. Shields, D.B. Cohen, and T.J. Orten. 1983. Chloroplast DNA evolution and the origin of amphidiploid *Brassica* species. *Theor. Appl. Genet.* 65:181-189.
- Pamilo, P., M. Nei, and W.-H. Li. 1987. Accumulation of mutations in sexual and asexual populations. *Genet. Res.* 49:135-146.
- Parkin, E. J., and R. K. Butlin. 2004. Within- and between-individual sequence variation among ITS1 copies in the meadow grasshopper *Chorthippus parallelus* indicates frequent intrachromosomal gene conversion. *Mol. Biol. Evol.* 21:1595-1601.
- Pelletier, G., M. Féral, J. Goujaud, F. Vedel, and M. Caboche. 1987. The use of rootless mutants for the screening of spontaneous androgenetic and gynogenetic

- haploids in *Nicotiana tabacum*: evidence for the direct transfer of cytoplasm. *Theor. Appl. Genet.* 75:13-15.
- Petit, R.J., A. Kremer, and D.B. Wagner. 1993. Geographic structure of chloroplast DNA polymorphisms in European oaks. *Theor. Appl. Genet.* 87:122-128.
- Pichot, C., M. El Maâtaoui, S. Raddi, and P. Raddi. 2001. Surrogate mother for endangered *Cupressus*. *Nature* 412:39.
- Pichot, C., B. Liens, J.L.R. Nava, J.B. Bachelier, and M. El Maâtaoui. 2008. Cypress surrogate mother produces haploid progeny from alien pollen. *Genetics* 178:379-383.
- Poon, A. and S.P. Otto. 2000. Compensating for our load of mutations: freezing the meltdown of small populations. *Evolution* 54:1467-1479.
- Posada, D., and K. A. Crandall. 1998. MODELTEST: testing the model of DNA substitution. *Bioinformatics* 14:817-818.
- Posada, D. and K.A. Crandall. 2001. Evaluation of methods for detecting recombination from DNA sequences: Computer simulations. *Proc. Natl. Acad. Sci.* 98: 13757-13762.
- Pouchkina-Stantcheva, N.N., B.M. McGee, C. Boschetti, D. Tolleter, S. Chakrabortee, A. Popova, F. Meersman, D. Macherel, D.K. Hinch, and A. Tunnacliffe. 2007. Functional divergence of formal alleles in an ancient asexual invertebrate. *Science* 318: 268-271.
- Prashad, B. 1933. Revision of the Asiatic species of the genus *Corbicula* I. The Indian Species of *Corbicula*. *Memoirs of the Indian Museum* 9:13-27.
- Qiu, A.D., A.J. Shi, and A. Komaru. 2001. Yellow and brown shell color morphs of *Corbicula fluminea* (Bivalvia: Corbiculidae) from Sichuan Province, China, are triploids and tetraploids. *J. Shellfish Res.* 20:323-328.
- Quattro, J.M., J.C. Avise, and R.C. Vrijenhoek. 1991. Molecular evidence for multiple origins of hybridogenetic fish clones (Poeciliidae: *Poeciliopsis*). *Genetics* 127:391-398.
- Rambaut, A. 2006. FigTree v1.2.2. Institute of Evolutionary Biology, University of Edinburgh.
- Rambaut, A. and N.C. Grassly. 1997. Seq-Gen: an application for the Monte Carlo simulation of molecular sequence evolution along phylogenetic trees. *Comput. Appl. Biosci.* 13:235-238.
- Rapacz, M., D. Gasiór, M. Humphreys, Z. Zwierzykowski, A. Plazek, and A. Lesniewska-Bocianowska. 2005. Variation for winter hardiness generated by androgenesis from *Festuca pratensis* x *Lolium multiflorum* amphidiploid cultivars with different winter susceptibility. *Euphytica* 142:65-73.
- Renard, E., V. Bachmann, M.L. Cariou, and J.C. Moreteau. 2000. Morphological and molecular differentiation of invasive freshwater species of the genus *Corbicula* (Bivalvia, Corbiculidae) suggest the presence of three taxa in French rivers. *Mol. Ecol.* 9:2009-2016.

- Rieseberg, L.H. and S.J. Brunnsfeld. 1992. Molecular evidence and plant introgression. Pages 151-176 in *Molecular Systematics of Plants* (P.S. Soltis, D.E. Soltis, and J.J. Doyle, eds.). Chapman and Hall, New York.
- Rieseberg, L.H. and D.E. Soltis. 1991. Phylogenetic consequences of cytoplasmic gene flow in plants. *Evol. Trends Plants* 5:65-84.
- Rieseberg, L. H., J. Whitton, and K. Gardner. 1999. Hybrid zones and the genetic architecture of a barrier to gene flow between two sunflower species. *Genetics* 152:713-727.
- Rieseberg, L.H., J. Whitton, and C.R. Linder. 1996. Molecular marker incongruence in plant hybrid zones and phylogenetic trees. *Acta Bot. Neerl.* 45:243-262.
- Rokas, A., B.L. Williams, N. King, and S.B. Carroll. 2003. Genome-scale approaches to resolving incongruence in molecular phylogenies. *Nature* 425:798–804.
- Ronquist, F. and J.P. Huelsenbeck. 2003. MRBAYES 3: Bayesian phylogenetic inference under mixed models. *Bioinformatics* 19:1572-1574.
- Satta, Y., N. Toyohara, C. Ohtaka, Y. Tatsuno, T. K. Watanabe, E. T. Matsuura, S. I. Chigusa, and N. Takahata. 1988. Dubious maternal inheritance of mitochondrial DNA in *D. simulans* and evolution of *D. mauritiana*. *Genet. Res.* 52:1-6.
- Schartl, M., I. Nanda, I. Schlupp, B. Wilde, J.T. Epplen, M. Schmid, and J. Parzefall, 1995a. Incorporation of subgenomic amounts of DNA as compensation for mutational load in a gynogenetic fish. *Nature* 373, 68–71.
- Schartl, M., B. Wilde, I. Schlupp, and J. Parzefall. 1995b. Evolutionary origin of a parthenoform, the Amazon molly *Poecilia formosa*, on the basis of a molecular genealogy. *Evolution* 49(5): 827-835.
- Schlupp, I., I. Nanda, M. Dobler, D.K. Lamatsch, J.T. Epplen, J. Parzefall, M. Schmid, and M. Schartl. 1998. Dispensable and indispensable genes in an asexual fish, the Amazon molly *Poecilia formosa*. *Cytogenetics and Cell Genetics* 80, 193–198.
- Schnable, P.S. and R.P. Wise. 1998. The molecular basis of cytoplasmic male sterility and fertility restoration. *Trends Plant Sci.* 3:175-180.
- Siller, S. 2001. Sexual selection and the maintenance of sex. *Nature* 411:689-692.
- Siripatrawan, S., J.-K. Park, and D. Ó Foighil. 2000. Two lineages of the introduced Asian freshwater clam *Corbicula* occur in North America. *J. Molluscan Stud.* 66:423-429.
- Smith, M.H., J. Britton, P. Burke, R.K. Chesser, M.W. Smith, and J. Hagen. 1979. Genetic variability in *Corbicula*, an invading species. Pp. 243-248 in *Proceedings, First International Corbicula Symposium* (J.C. Britton, ed.). Texas Christian University Research Foundation, Fort Worth, Texas.
- Southern, E.M. 1975. Detection of specific sequences among DNA fragments separated by gel electrophoresis. *J. Molec. Biol.* 98:503-517.
- Stepien, C.A., A.N. Hubers, and J.L. Skidmore. 1999. Diagnostic genetic markers and evolutionary relationships among invasive dreissenoid and corbiculoid bivalves in North America: phylogenetic signal from mitochondrial 16S rDNA. *Mol. Phyl. Evol.* 13:31-49.

- Sullivan, J. P., S. Lavoué, M. E. Arnegard, and C. D. Hopkins. 2004. AFLPs resolve phylogeny and reveal mitochondrial introgression within a species flock of African electric fish (Mormyroidea: Teleostei). *Evolution* 58:825-841.
- Surani, M.A.H., S.C. Barton, and M.L. Norris. 1984. Development of reconstituted mouse eggs suggests imprinting of the genome during gametogenesis. *Nature* 308:548-550.
- Szollosi, G.J., I. Derenyi, and T. Vellai. 2006. The maintenance of sex in bacteria is ensured by its potential to reload genes. *Genetics* 174:2173-2180.
- Swofford, D.L. 2002. PAUP*: Phylogenetic Analysis Using Parsimony (*and other methods). Sinauer Associates, Sunderland, MA.
- Swofford, D.L., G.J. Olsen, P.J. Waddell, and D.M. Hillis. 1996. Phylogenetic inference. Pp. 407-514 in *Molecular Systematics* (D.M. Hillis, C. Moritz, and B.K. Mable, eds.). Sunderland: Sinauer Assoc., Inc.
- Tindall, K.R. and T.A. Kunkel. 1988. Fidelity of DNA synthesis by the *Thermus aquaticus* DNA polymerase. *Biochemistry* 27:6008-6013.
- Tsitronis, A., M. Kirkpatrick, and D.A. Levin. 2003. A model for chloroplast capture. *Evolution* 57:1776-1782.
- Van Valen, L. 1973. A new evolutionary law. *Evolutionary Theory* 1: 1-30.
- Vrijenhoek, R.C. 1994. Unisexual fish: model systems for studying ecology and evolution. *Annu. Rev. Ecol. Syst.* 25:71-96.
- Wagner, G.P. and W. Gabriel. 1990. Quantitative variation in finite parthenogenetic populations: what stops Muller's ratchet in the absence of recombination? *Evolution* 44:715-731.
- Watt, E.M. and V.M. Watt. 1992. DNA fingerprinting from minimal blood volumes. *Molec. Ecol.* 1:131-132.
- Wendel, J. F. and J. J. Doyle. 1998. Phylogenetic incongruence: window into genome history and molecular evolution. Pages 265-296 in *Molecular Systematics of Plants II: DNA sequencing* (D. E. Soltis, P.S. Soltis, and J. J. Doyle, eds.). Kluwer Academic Publ., Boston.
- Wendel, J. F., J. M. Stewart, and J. H. Rettig. 1991. Molecular evidence for homoploid reticulate evolution among Australian species of *Gossypium*. *Evolution* 45:694-711.
- West, S.A., C.M. Lively, and A.F. Read. 1999. A pluralist approach to sex and recombination. *J. Evol. Biol.* 12:1003-1012.
- Whittemore, A. T., and B. A. Schaal. 1991. Interspecific gene flow in sympatric oaks. *Proc. Natl. Acad. Sci. USA* 88: 2540-2544.
- Zeyl, C.M., M. Mizesko, and J.A.G.M. DeVisser. 2001. Mutational meltdown in laboratory yeast populations. *Evolution* 55:909-917.
- Zouros, E., K. R. Freeman, A. O. Ball, and G. H. Pogson. 1992. Direct evidence for extensive paternal mitochondrial DNA inheritance in the marine mussel *Mytilus*. *Nature* 359:412-414.

Zwickl, D. J. 2006. Genetic algorithm approaches for the phylogenetic analysis of large biological sequence datasets under the maximum likelihood criterion. Ph.D. dissertation, the University of Texas at Austin.

VITA

Shannon M. Hedtke graduated from Wayzata Senior High School in Wayzata, Minnesota in 1990. She received the degree of Bachelor of Arts in History with honors from Grinnell College in Grinnell, Iowa in December, 1993. In the following years she was variously employed doing music transcription in Indianapolis, Indiana, managing a soccer store in Duluth, Minnesota, and supervising reference and circulation at the Music Library of Cornell University, Ithaca, New York. In 1996 she began taking courses at Cornell. She held a traineeship at the National Zoo's Genetics Lab, Washington, D.C. in the summer of 2000, and began working as a laboratory technician at Cornell University in 2001. In August, 2002, she entered the Graduate School at The University of Texas at Austin.

Permanent address: 1608 Broadmoor Dr., Austin, Texas, 78723

This manuscript was typed by the author.